

DATASHEET

Floor Heating Manifold FHF

Application

The Manifold FHF is used for controlling water flow in under floor heating systems. Each tube of the floor heating system is connected to the manifold, thus making it possible to control water flow or heat supply to each room in the building individually.

The manifold consists of a supply and return manifold. The supply manifold includes possibility for individual shut-off of each circuit and as an option also flowmeter. The return manifold is equipped with integrated Danfoss pre-setting valves securing optimal hydraulic balance in the system.

The valves can be controlled electronically by thermal actuators or act as self-acting units by means of remote temperature adjusters.

The manifold is supplied in modules of up to 12 outlets. In addition extension pieces are available for connecting the manifolds in series. Ball valves are available as an option for positive shut-off between manifold and system.

The end pieces FHF-EM and FHF-EA are supplied with manual airvent or alternatively with automatic airvent, purge valve. The end pieces are placed at the end of the manifold.

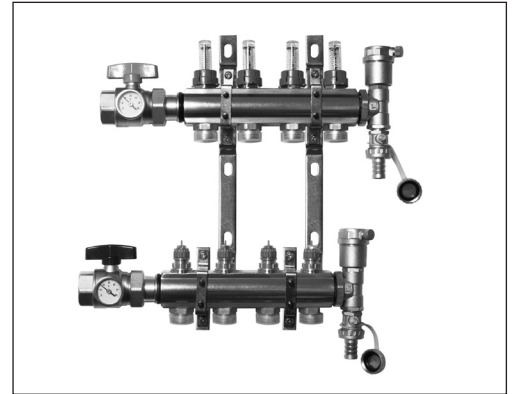

Manifold with flowmeter

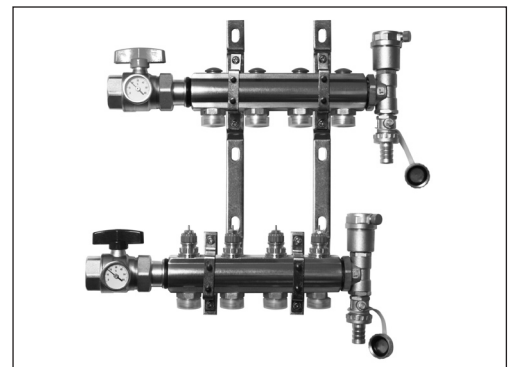

Manifold without flowmeter



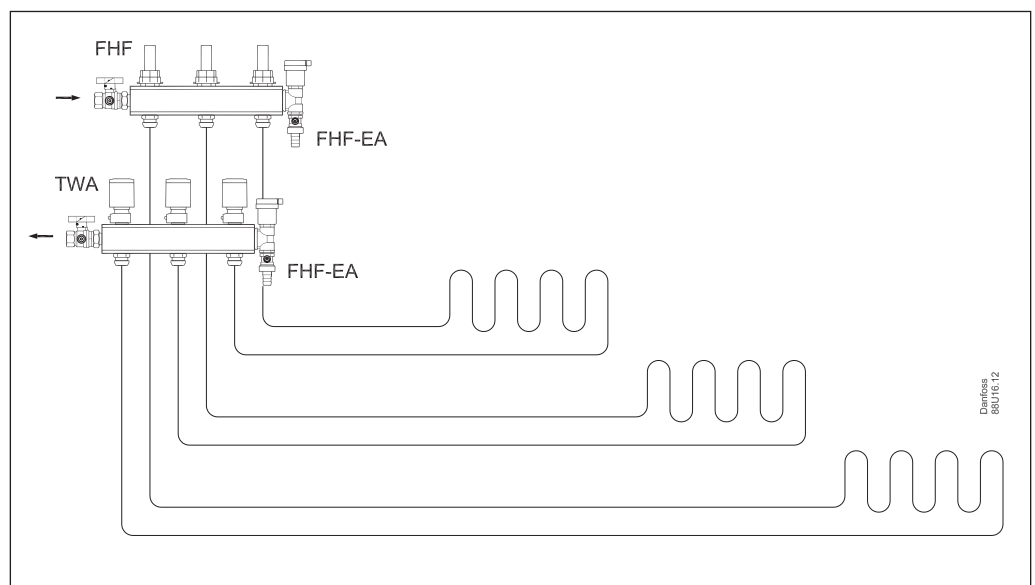

System layout



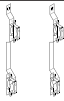
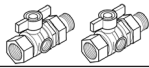

Ordering

	Description	Type	Code no.
	Manifold set 2+2	FHF-2	088U0502
	Manifold set 3+3	FHF-3	088U0503
	Manifold set 4+4	FHF-4	088U0504
	Manifold set 5+5	FHF-5	088U0505
	Manifold set 6+6	FHF-6	088U0506
	Manifold set 7+7	FHF-7	088U0507
	Manifold set 8+8	FHF-8	088U0508
	Manifold set 9+9	FHF-9	088U0509
	Manifold set 10+10	FHF-10	088U0510
	Manifold set 11+11	FHF-11	088U0511
	Manifold set 12+12	FHF-12	088U0512
	Manifold set 2+2, with flowmeter	FHF-2F	088U0522
	Manifold set 3+3, with flowmeter	FHF-3F	088U0523
	Manifold set 4+4, with flowmeter	FHF-4F	088U0524
	Manifold set 5+5, with flowmeter	FHF-5F	088U0525
	Manifold set 6+6, with flowmeter	FHF-6F	088U0526
	Manifold set 7+7, with flowmeter	FHF-7F	088U0527
	Manifold set 8+8, with flowmeter	FHF-8F	088U0528
	Manifold set 9+9, with flowmeter	FHF-9F	088U0529
	Manifold set 10+10, with flowmeter	FHF-10F	088U0530
	Manifold set 11+11, with flowmeter	FHF-11F	088U0531
	Manifold set 12+12, with flowmeter	FHF-12F	088U0532
	End section - automatic airvent and purge valve	FHF-EA	088U0580
	End section - manual airvent and purge valve	FHF-EM	088U0581
	End caps -set	FHF-E	088U0582
	Connection pieces - set	FHF-C	088U0583
	Reduction bushes/pieces -set 1" - 3/4"	FHF-R	088U0584

Ordering

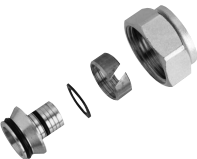
	Description	Type	Code no.
	Mounting brackets - set	FHF-MB	088U0585
	2 x ball valve 1" with tail piece - for connection to manifold and for blocking of floor heating system	FHF-BV	088U0586
	1 x thermometer 0-60°C Ø35mm - for flow/return temperature measurement	FHD-T	088U0029
	Thermal actuator, 24V, NC, Danfoss RA connection to valve	TWA-A	088H3110
	Thermal actuator, 230V, NC, Danfoss RA connection to valve	TWA-A	088H3112
	Thermal actuator, 24V, NC, with end switch, Danfoss RA connection to valve	TWA-A	088H3114

	Description	Type	Code no.
	<p>Compression fittings for PEX tubing in accordance with DIN 16892/16893.</p> <p>Max working pressure - 6 bar Test pressure - 10 bar Max flow temp. - 95 °C G 3/4" Internal thread</p> <p>Max flow temperature given by the tube manufacturer must not be exceeded.</p>	12x2 mm	013G4152
		13x2 mm	013G4153
		14x2 mm	013G4154
		15x2,5 mm	013G4155
		16x1,5 mm	013G4157
		16x2 mm	013G4156
		16x2,2 mm	013G4163
		17x2 mm	013G4162
		18x2 mm	013G4158
		18x2,5 mm	013G4159
		20x2 mm	013G4160
20x2,5 mm	013G4161		
	<p>Compression fittings for ALUPEX tubing.</p> <p>Max working pressure - 6 bar Test pressure - 10 bar Max flow temp. - 95 °C G 3/4" Internal thread</p> <p>Max flow temperature given by the tube manufacturer must not be exceeded.</p>	12x2 mm	013G4182
		14x2 mm	013G4184
		15x2,5 mm	013G4185
		16x2 mm	013G4186
		16x2,25 mm	013G4187
		18x2 mm	013G4188
		20x2 mm	013G4190
20x2,5 mm	013G4191		
	<p>Compression fittings for STEEL and COPPER tubing.</p> <p>Max working pressure - 6 bar Test pressure - 10 bar Max flow temp. - 120 °C G 3/4" Internal thread</p>	10 mm	013G4120
		12 mm	013G4122
		14 mm	013G4124
		15 mm	013G4125
		16 mm	013G4126
18 mm	013G4128		

Capacity/ commissioning

The pre-setting of the manifold valves determines the flow in the floor heating tubes and is therefore an important factor for obtaining optimal hydraulic balance in the system. A correct hydraulic balance is important if optimal comfort shall be achieved with a minimum of energy consumption and is easily carried out following the example shown below.

Room 1		Example
1	Determine longest tube/largest room	25 m ²
2	Desired cooling (dT)	5 °C (typical)
3	Determine heat requirement for the room	50 W/m ²
4	Conversion factor	1,16
5	Calculation of flow for the room	$Q \text{ (l/h)} = \frac{50 \text{ W/m}^2 \times 25 \text{ m}^2}{5 \text{ °C} \times 1,16}$ $Q \text{ (l/h)} = \underline{216 \text{ l/h}}$
Room 2		
6	Determine area for the next room	15 m ²
7	Calculation of flow for the room (dT and heat requirement is assumed identical for the rooms in this case)	$Q \text{ (l/h)} = \frac{50 \text{ W/m}^2 \times 15 \text{ m}^2}{5 \text{ °C} \times 1,16}$ $Q \text{ (l/h)} = \underline{129 \text{ l/h}}$

Pre-setting for manifold with flowmeter:

Room 1 → N
Room 2 → 5

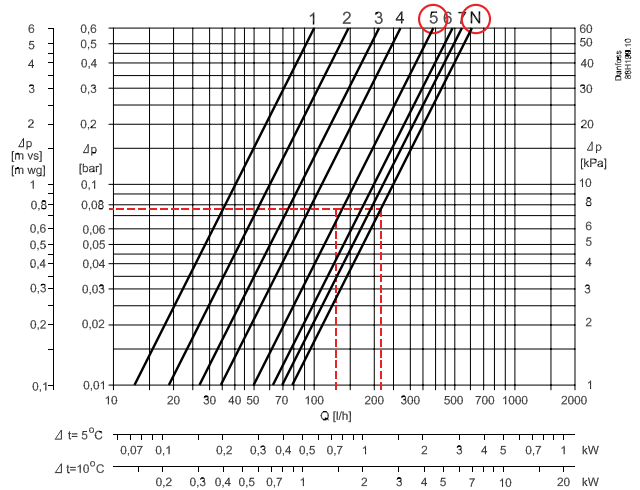

Manifold with flowmeter

Pre-setting for manifold without flowmeter:

Room 1 → N
Room 2 → 6

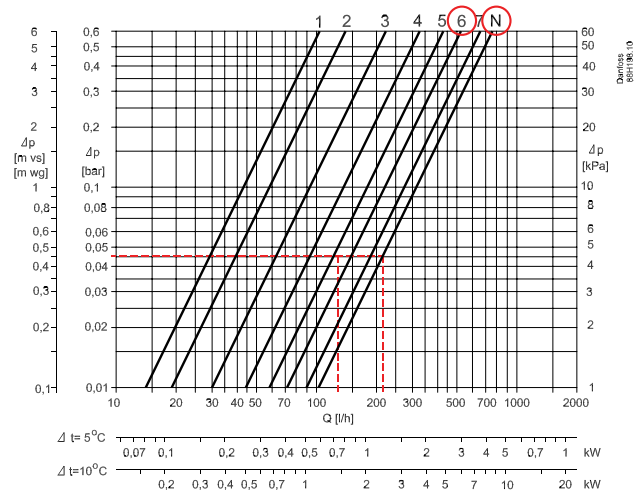

Manifold without flowmeter

Pre-setting the manifold valves

The diagrams shows the capacities for each heating circuit at different pre-settings of the manifold valves. Please note that the capacities are slightly different depending on whether a manifold with flowmeter or a manifold without

flowmeter has been chosen. Based on the above calculations and capacity diagrams each manifold valve is pre-set by rotating the red ring until the correct value on the ring is in-line with the sight mark on the valve.

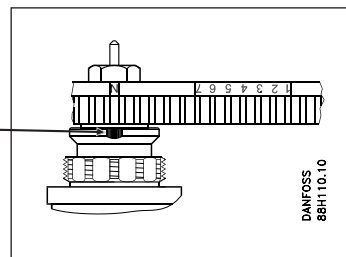
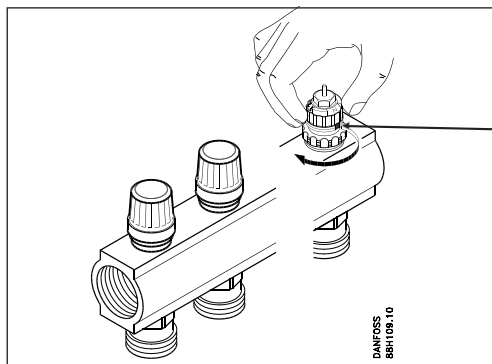

Design

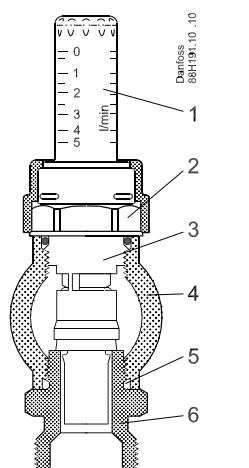

Supply manifold with flowmeter

Item	Description	Material
1	Sightglass	Heat resistant plastic
2	Flowmeter nut	Brass, CuZn39Pb3
3	Flowmeter insert	Brass, CuZn39Pb3
4	Supply manifold body	Brass, CuZn40Pb2
5	O-ring	EPDM
6	Union for compression fitting	Brass, CuZn40Pb2

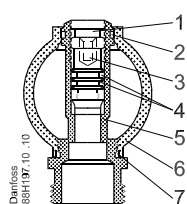

Supply manifold without flowmeter

Item	Description	Material
1	Lock washer	Brass, CuZn40Pb2
2	O-ring	EPDM
3	Valve spindle	Brass, CuZn40Pb2
4	O-ring	EPDM
5	Valve tube	Brass, CuZn40Pb2
6	Supply manifold body	Brass, CuZn40Pb2
7	O-ring	EPDM

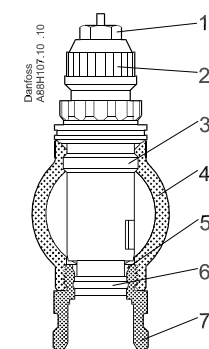

Return manifold with control valve

Item	Description	Material
1	Gland seal	-
2	Pre-setting ring	PBT
3	Valve body	Brass, CuZn40Pb2
4	Return manifold body	Brass, CuZn40Pb2
5	K _v insert	Brass, CuZn39Pb3
6	O-ring	EPDM
7	Union for compression fitting	Brass, CuZn40Pb2

Operation conditions

Max differential pressure 0,6 bar
 Max working pressure 10 bar/ 6 bar
 Max test pressure 16 bar/10 bar
 Max flow temperature 90 °C

Dimensions

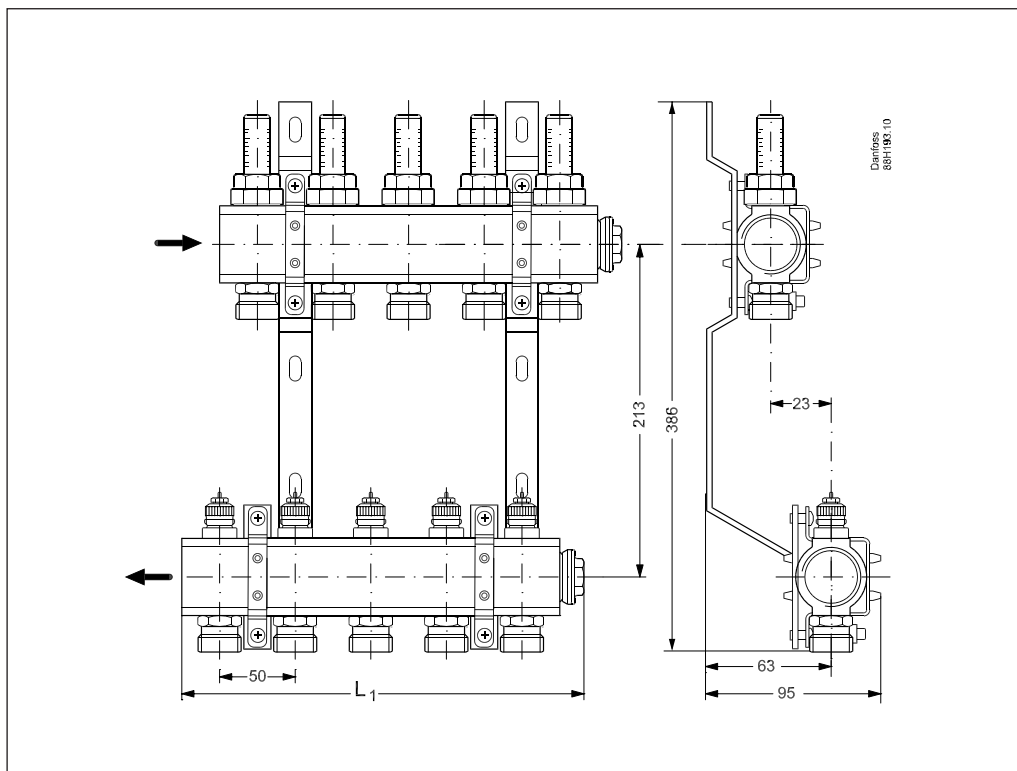

Type	2+2	3+3	4+4	5+5	6+6	7+7	8+8	9+9	10+10	11+11	12+12
L1 (mm)	111	161	211	261	311	361	411	461	511	561	611

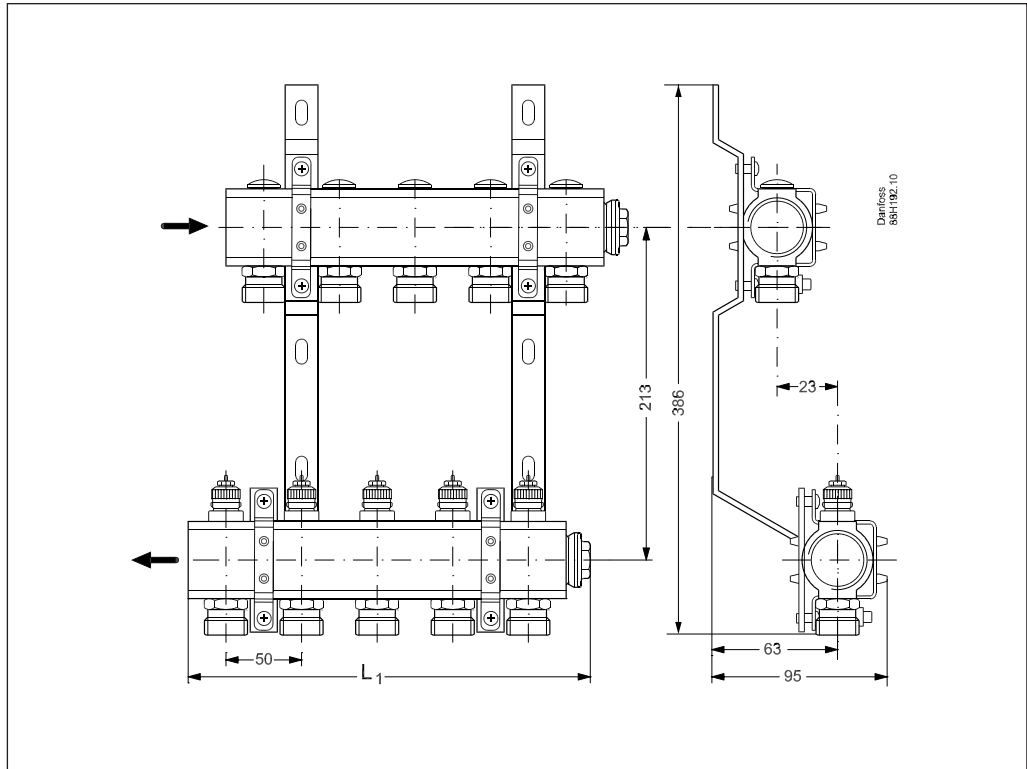

Type	2+2	3+3	4+4	5+5	6+6	7+7	8+8	9+9	10+10	11+11	12+12
L1 (mm)	111	161	211	261	311	361	411	461	511	561	611

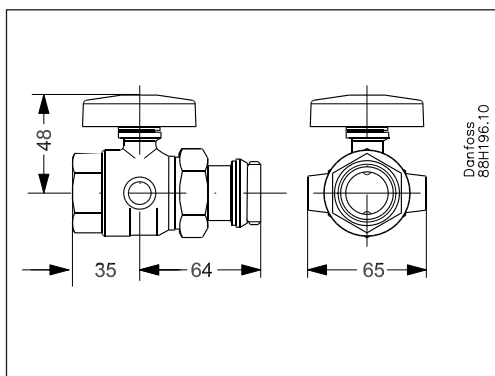
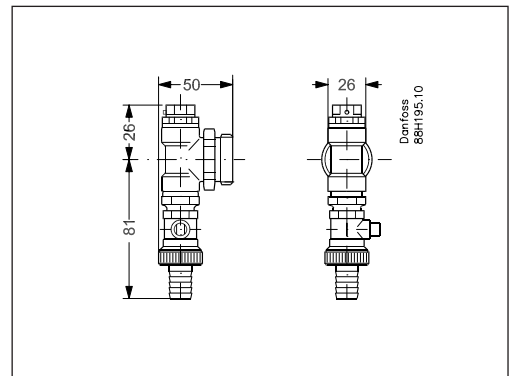
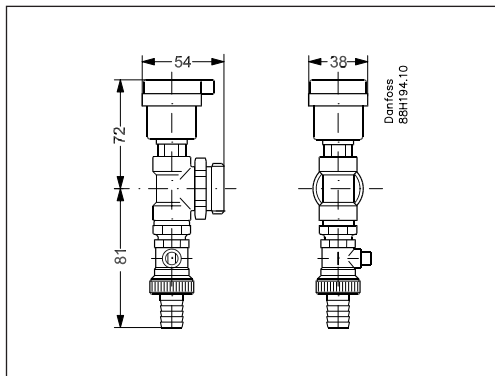

Danfoss can accept no responsibility for possible errors in catalogues, brochures and other printed material. Danfoss reserves the right to alter its products without notice. This also applies to products already on order provided that such alterations can be made without subsequential changes being necessary in specifications already agreed. All trademarks in this material are property of the respective companies. Danfoss and the Danfoss logotype are trademarks of Danfoss A/S. All rights reserved.

