

FAIRFIELD Torque-Hub® Planetary Final Drives

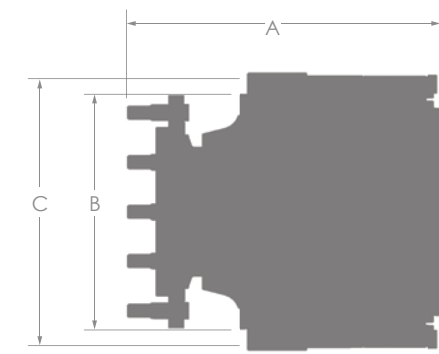

Spindle Flange Output

Model	Performance Data			Physical Data				
	Max. Cont. Torque lb-in (Nm)	Max. Intrmt. Torque lb-in (Nm)	Max. Input Speed (RPM)	Max. Radial Load lb (kg)	Nominal Ratio (x:1)	Overall Length in (mm) A	Pilot Mtg. in (mm) B	B.C. Diameter in (mm) C
S07B	7,500 (850)	15,000 (1,690)	4,000	4,000 (1,818.18)	4	9.26 (235.00)	4.00 (101.60)	7.50 (190.50)
S1B1	15,000 (1,690)	30,000 (3,390)	4,000	5,000 (2,272.73)	19 to 69	10.57 (268.48)	4.00 (101.66)	5.50 (139.70)
S1B9	15,000 (1,690)	30,000 (3,390)	4,000	6,000 (2,727.27)	19 to 69	10.56 (268.22)	4.62 (117.35)	6.00 (152.40)
S1E	15,000 (1,690)	30,000 (3,380)	5,000	7,000 (3,181.82)	3 to 6	8.00 (203.20)	4.00 (101.60)	5.50 (139.70)
S2B	25,000 (2,820)	50,000 (5,650)	4,000	13,000 (5,909.09)	14 to 50	12.59 (319.79)	7.00 (177.80)	8.25 (209.55)
S3B8	37,500 (4,240)	75,000 (8,470)	4,000	16,000 (7,272.73)	19 to 74	12.74 (323.60)	7.00 (177.80)	9.50 (241.30)
S6B3	60,000 (6,780)	120,000 (13,560)	5,000	18,000 (8,181.82)	13 to 42	15.88 (403.35)	7.00 (177.80)	9.50 (241.30)
S7B2	75,000 (8,470)	150,000 (16,950)	3,000	20,000 (9,090.91)	27 to 95	15.25 (387.35)	9.00 (228.60)	10.50 (266.70)
S10B4	125,000 (14,120)	250,000 (28,250)	1,800	30,000 (13,636.36)	44 to 124	18.16 (461.26)	9.50 (241.30)	12.00 (304.80)
S12B2	125,000 (14,120)	250,000 (28,250)	5,000	15,000 (6,818.18)	20, 29, 40	19.79 (502.67)	9.00 (228.60)	10.50 (266.70)
S16B2	160,000 (18,080)	320,000 (36,160)	4,000	15,000 (6,818.18)	20, 29, 40	20.11 (510.79)	9.00 (228.60)	10.50 (266.70)
S20B1	250,000 (28,250)	500,000 (56,490)	25,000	47,000 (21,363.64)	27 to 116	21.50 (546.10)	12.75 (323.85)	15.00 (381.00)
S25B4	200,000 (22,600)	400,000 (45,190)	3,000	34,000 (15,454.55)	19, 29, 36	22.01 (559.05)	11.00 (279.40)	12.75 (323.85)
S50B1	500,000 (56,490)	1,000,000 (112,980)	3,000	42,000 (19,090.91)	25 to 289	24.09 (611.89)	12.75 (323.85)	15.00 (381.00)
S40B1	400,000 (45,200)	800,000 (90,400)	3,000	30,000 (13,636.36)	25, 40	23.00 (584.20)	12.75 (323.85)	15.00 (381.00)
S80B2	800,000 (90,388)	1,600,000 (180,776)	40,000	50,000 (22,727.27)	36, 134, 144	31.80 (807.72)	9.84 (249.94)	13.78 (350.01)
S90B1	900,000 (101,690)	180,000 (203,370)	2,000	60,000 (27,272.73)	26	32.40 (822.96)	15.75 (400.05)	18.11 (459.99)



Spindle Flange Output

Shaft Output

Model	Performance Data			Physical Data					
	Max. Cont. Torque lb-in (Nm)	Max. Intrmt. Torque lb-in (Nm)	Max. Input Speed (RPM)	Max. Radial Load lb (kg)	Nominal Ratio (x:1)	Overall Length in (mm) A	Pilot Mtg. in (mm) B	B.C. Diameter in (mm) C	Shaft Diam. in (mm)
S07A	7,500 (850)	15,000 (1,690)	4,000	4,000 (1,818.18)	4	9.86 (250.44)	6.50 (165.10)	7.50 (190.50)	1.75 (44.45)
S1A1/A2	15,000 (1,690)	30,000 (3,390)	4,000	7,000 (3,181.82)	19 to 69	11.90 (302.26)	8.56 (217.42)	9.50 (241.30)	2.00 (50.80)
S1C5	15,000 (1,690)	30,000 (3,390)	5,000	7,000 (3,181.82)	4 to 6	11.02 (279.91)	5.40 (137.16)	7.25 (184.15)	2.00 (50.80)
S1CK/CL	15,000 (1,690)	30,000 (3,390)	5,000	7,000 (3,181.82)	4 to 6	12.83 (325.88)	5.00 (127.00)	6.37 (161.80)	2.25 (57.15)
S2A3	25,000 (2,820)	50,000 (5,650)	4,000	15,000 (6,818.18)	14 to 50	17.16 (435.86)	8.25 (209.55)	10.10 (256.54)	2.98 (75.69)
S3A6	37,500 (4,240)	75,000 (8,470)	4,000	16,000 (7,272.73)	19 to 74	13.68 (347.47)	8.25 (209.55)	10.10 (256.54)	2.98 (75.69)
S6A1/A2	60,000 (6,780)	120,000 (13,560)	5,000	15,500 (7,045.45)	13 to 42	15.84 (402.34)	11.00 (279.40)	13.19 (335.03)	3.00 (76.20)
S6C7	60,000 (6,780)	120,000 (13,560)	2,500	15,500 (7,045.45)	3 to 6	14.57 (370.08)	11.00 (279.40)	13.19 (335.03)	3.00 (76.20)
S7AB	75,000 (8,470)	150,000 (16,950)	3,000	20,000 (9,090.91)	27 to 95	18.10 (459.74)	15.00 (381.00)	16.75 (425.25)	3.50 (88.90)
S7A1/A2	75,000 (8,470)	150,000 (16,950)	3,000	20,000 (9,090.91)	27 to 95	18.10 (459.74)	12.50 (317.50)	13.63 (346.20)	3.75 (95.25)
S10A1/A2	125,000 (14,120)	250,000 (28,250)	1,800	30,000 (13,636.36)	44 to 124	21.30 (541.02)	18.26 (463.80)	19.75 (501.55)	4.33 (109.98)
S12A1/A2	125,000 (14,120)	250,000 (28,250)	4,000	15,000 (6,818.18)	20, 29, 40	19.87 (504.70)	12.50 (317.50)	13.63 (346.20)	3.50 (88.90)
S16A4/A6	160,000 (18,080)	320,000 (36,160)	4,000	20,000 (9,090.91)	20, 29, 40	23.61 (599.69)	12.50 (317.50)	13.63 (346.20)	3.50 (88.90)
S20A1	250,000 (28,250)	500,000 (56,490)	1,800	42,000 (19,090.91)	27 to 116	25.20 (640.08)	19.00 (482.60)	21.90 (556.26)	5.13 (130.03)
S25A1	200,000 (22,600)	400,000 (45,190)	3,000	30,000 (13,636.36)	19, 29, 36	23.40 (594.36)	18.26 (463.80)	19.75 (501.65)	4.33 (109.98)
S40A	400,000 (45,198)	800,000 (90,395)	3,000	30,000 (13,636.36)	25 to 40	26.70 (678.18)	21.40 (543.56)	22.39 (568.58)	5.12 (130.05)
S50A1	500,000 (56,490)	1,000,000 (113,000)	3,000	30,000 (13,636.36)	25 to 289	27.80 (706.12)	19.00 (482.60)	21.99 (558.55)	5.13 (130.30)

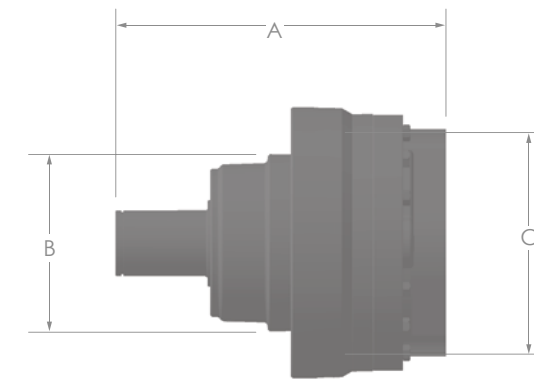

Shaft Output

oerlikon
fairfield

Oerlikon Fairfield
U.S. 52 South
P.O. Box 7940
Lafayette, Indiana 47903-7940 USA
765.772.4000
765.772.4001 (fax)
www.fairfieldmfg.com

oerlikon
graziano

Oerlikon Graziano
Via Cumiana, 14
10098 Cascine Vica – Rivoli
Torino Italy
+39 011 9570 1
+39 011 958 4803 (fax)
oerlikon.com

* Contact Oerlikon Fairfield for accurate and precise dimensions.

▣ Lafayette IN 1108 Par 1M



FAIRFIELD Torque-Hub®

More Power in a Smaller, Lighter and More Efficient Design

For Industrial Machinery and Mobile Equipment

Fairfield Torque-Hub® final drives deliver the torque output and long-life performance required for industrial machinery and off-highway mobile equipment.

Standard input configurations and a choice of shaft, spindle or wheel drive output options combine to meet the needs of many power transmission applications. In addition, standard SAE hydraulic motor mounting provisions accommodate nearly any hydraulic motor.

The application flexibility provided by these features and the broad range of torque outputs and gear ratios available have helped to make Fairfield Torque-Hub® the preferred final drives of manufacturers throughout the world. Our customers include the world's leading manufacturers of agricultural and construction equipment, conveyors, augers, mixers, wire drawing, capstan winches, metal roll bending machinery, garbage shredders, aerators and many other types of specialized products.

Wheel Drive, Shaft or Spindle Outputs

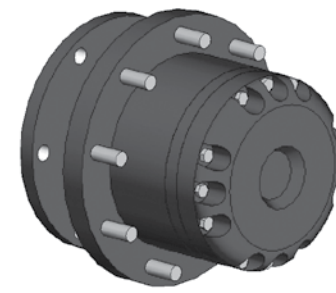

Wheel Drive

Ideal for propelling off-highway equipment, Fairfield Torque-Hub® wheel drives are also used to power winches and many marine applications. Wheel drives allow the design engineer greater flexibility to economically deliver power where it is needed.

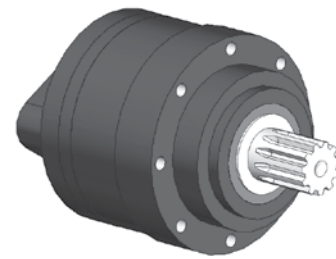

Shaft Output

Shaft outputs facilitate the delivery of power to remote in-plant machinery such as conveyors, mixers and augers. They also meet remote power requirements such as swing drives on mobile man-lifts, cranes, excavators and logging equipment.

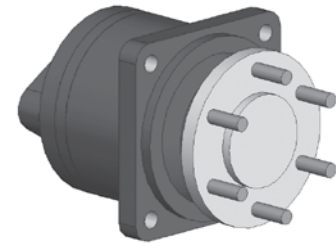

Spindle Output

Spindle outputs are used to power the drive wheels of vehicles with small-diameter wheels, such as small lift trucks and mowers. They meet many other requirements where a flange mount is more desirable.

Gearing to Meet Your Torque and Speed Requirements

Fairfield Torque-Hub® drives are available in single planetary, double planetary, triple planetary and differential planetary gearing configurations to meet your torque and operating speed requirements.

For more specific dimensional information, contact your Fairfield representative or see the appropriate series catalog.



Wheel Drive Products

Model	Performance Data			Physical Data				
	Max. Cont. Torque lb-in (Nm)	Max. Intrmt. Torque lb-in (Nm)	Max. Input Speed (RPM)	Max. Radial Load lb (kg)	Nominal Ratio (x:1)	Overall Length in (mm) A	Pilot Mtg. in (mm) B	B.C. Diameter in (mm) C
W07A	7,500 (850)	15,000 (1,690)	1,500	5,800 (2,636.36)	4	8.70 (220.98)	6.00 (152.40)	8.00 (203.20)
W1A	15,000 (1,690)	30,000 (3,390)	4,000	5,500 (2,500.00)	8 to 68	10.36 (263.14)	7.90 (200.66)	9.50 (241.30)
W1BF	15,000 (1,690)	30,000 (3,390)	4,000	5,500 (2,500.00)	18 to 68	10.30 (261.62)	7.90 (200.66)	9.50 (241.30)
W2B2	25,000 (2,820)	50,000 (5,650)	4,000	12,500 (5,681.82)	13 to 68	11.20 (284.48)	9.50 (241.30)	11.12 (282.45)
7HBO	30,000 (3,500)	60,000 (7,000)	5,000	5,500 (2,500.00)	19 to 132	9.30 (236.22)	7.89 (200.28)	9.50 (241.30)
7HBA	30,000 (3,500)	60,000 (7,000)	5,000	14,000 (6,363.64)	19 to 132	9.30 (236.22)	7.89 (200.28)	9.50 (241.30)
7HP	30,000 (3,500)	60,000 (7,000)	5,000	14,000 (6,363.64)	19 to 132	10.68 (271.27)	7.89 (200.28)	9.50 (241.30)
7HLH	30,000 (3,500)	60,000 (7,000)	4,000	14,000 (6,363.64)	19 to 132	9.91 (251.71)	7.89 (200.28)	9.50 (241.30)
W3B1	37,500 (4,240)	75,000 (8,470)	4,000	14,400 (6,545.45)	18 to 73	12.20 (309.88)	11.02 (279.91)	13.18 (334.77)
W3C	37,500 (4,240)	75,000 (8,470)	4,000	14,400 (6,545.45)	18 to 73	12.20 (309.88)	11.02 (279.91)	13.18 (334.77)
11HBO	48,675 (5,500)	97,350 (11,000)	5,000	14,000 (6,363.64)	15 to 121	11.30 (287.02)	9.45 (240.03)	11.13 (282.58)
11HBA	48,675 (5,500)	97,350 (11,000)	5,000	16,000 (7,272.73)	15 to 121	11.30 (287.02)	9.45 (240.03)	11.13 (282.58)
11HCE	48,675 (5,500)	97,350 (11,000)	5,000	16,000 (7,272.73)	15 to 121	11.50 (292.10)	9.45 (240.03)	11.13 (282.58)
11HPA	48,675 (5,500)	97,350 (11,000)	5,000	16,000 (7,272.73)	15 to 121	11.40 (289.56)	9.45 (240.03)	11.13 (282.58)
11HPE	48,675 (5,500)	97,350 (11,000)	5,000	16,000 (7,272.73)	15 to 121	11.81 (299.97)	9.45 (240.03)	11.13 (282.58)
W5	50,000 (5,650)	100,000 (11,300)	4,000	14,000 (6,363.64)	15 to 49	11.02 (279.91)	13.18 (334.77)	12.56 (319.03)
W6C1	60,000 (6,780)	120,000 (13,560)	5,000	8,000 (3,636.36)	13 to 116	13.00 (330.20)	11.02 (279.91)	13.18 (334.77)
W7C	75,000 (8,470)	150,000 (16,950)	3,000	20,000 (9,090.91)	26 to 94	15.00 (381.00)	14.50 (368.30)	16.75 (425.45)
W10C2	125,000 (14,120)	250,000 (28,250)	1,800	30,000 (13,636.36)	43 to 123	17.60 (447.04)	17.50 (444.50)	19.75 (501.65)
W12C3	125,000 (14,120)	250,000 (28,250)	5,000	20,000 (9,090.91)	20, 29, 40	19.10 (485.14)	14.50 (368.30)	16.75 (425.45)
W16C3	160,000 (18,080)	320,000 (36,160)	4,000	26,000 (11,818.18)	20, 29, 40	19.03 (483.36)	14.44 (366.78)	16.75 (425.45)
W20D1	250,000 (28,250)	500,000 (56,490)	1,800	42,000 (19,090.91)	26 to 115	20.70 (525.78)	19.00 (590.80)	21.90 (556.26)
W25D4	200,000 (22,600)	400,000 (45,190)	3,000	30,000 (13,636.36)	19 to 88	19.47 (494.54)	17.50 (444.50)	19.75 (501.65)
W40D2	400,000 (45,200)	800,000 (90,400)	2,500	30,000 (13,636.36)	18 to 40	23.52 (597.41)	20.87 (529.97)	22.39 (568.58)
W50D9	500,000 (56,490)	1,000,000 (112,980)	3,000	30,000 (13,636.36)	18 to 40	24.20 (614.68)	19.00 (482.50)	21.90 (556.26)
W80D1	800,000 (90,388)	1,600,000 (180,776)	2,500	30,000 (13,636.36)	20, 35	24.09 (611.89)	23.26 (290.80)	25.25 (641.35)
W90	1,470,000 (166,090)	2,940,000 (332,290)	*	*	25 to 151	43.40 (1,102.36)	22.84 (580.14)	25.78 (654.81)

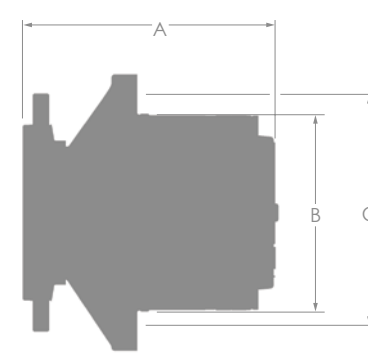

Wheel Drive Products

CT/CW Track/Wheel Drives

Performance and Physical Data							
Model	Torque Intermittent Nm	Length Torque lb-in (Nm) L	Nominal Ratio (x:1)	Model	Torque Rating Nm	Length Torque lb-in (Nm) L	Ratio (x:1)
CT18C	18,000	12.29 (312.17)	64 to 136	CW12	12,000	10.91 (277.11)	18 to 51
CT26	26,000	13.94 (354.08)	51 to 202	CW18	18,000	11.35 (288.29)	26 to 51
CT35	35,000	14.13 (358.90)	63 to 136	Contact Oerlikon Fairfield for accurate and precise dimensions.			
CT45	45,000	14.26 (362.20)	63 to 136				
CT50	50,000	14.64 (371.86)	69 to 169				

Right Angle Drives

Performance Data			Physical Data		
Model	Max. Cont. Output Torque lb-in (Nm)	Max. Input Speed (RPM)	Ratio (x:1)	Overall Length in (mm) A	Shaft Diameter in (mm)
RA701, 02 & 05	3,700 (420)	3,400	1	8.31 (211.07)	1.25 (31.75)
RA703 & 06	3,700 (420)	3,400	1	8.31 (211.07)	1.75 (44.45)
RA708	1,800 (200)	3,000	1.53	11.25 (285.75)	1.75 (44.45)
RA15	12,250 (1,384)	3,000	1.36	12.50 (317.50)	1.75 (44.45)



CT/CW Track/Wheel Drives

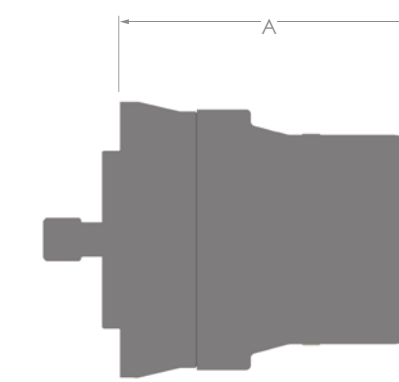

Right Angle Drives

T2 Two-Speed Drives

Performance Data			Physical Data			
Model	Max. Cont. Input Torque lb-in (Nm)	Max. Input Speed (RPM)	Nominal Ratio (x:1)	Overall Length in (mm) A	Pilot Mtg. in (mm) B	B.C. Diameter in (mm) C
T2A	2,500 (280)	3,500	3.5 to 4	8.07 (204.98)	6.00 (152.40)	9.00 (228.60)
T2B	4,000 (450)	3,750	3.5 to 4	9.11 (231.39)	6.00 (152.40)	9.00 (228.60)

Torque II Two-Speed Drives

Performance Data				Physical Data				
Model	Max. Cont. Torque lb-in (Nm)	Max. Intrmt. Torque lb-in (Nm)	Max. Input Speed (RPM)	Max. Radial Load lb (kg)	Nominal Ratio (x:1)	Overall Length in (mm) A	Pilot Mtg. in (mm) B	B.C. Diameter in (mm) C
W9T	90,000 (10,170)	180,000 (20,340)	3,750	27,000 (12,272.73)	35	12.20 (309.88)	12.00 (304.80)	14.17 (359.92)
W12T	125,000 (14,120)	250,000 (28,250)	3,750	36,000 (16,363.64)	20, 29, 40	16.80 (426.72)	14.50 (368.30)	16.75 (425.45)
W16T	160,000 (18,080)	320,000 (36,160)	3,750	36,000 (16,363.64)	20, 29, 40	16.80 (426.72)	14.50 (368.30)	16.75 (425.45)

Special Add-On Adaptors

Performance Data				Physical Data					
Model	Max. Cont. Torque lb-in (Nm)	Max. Intrmt. Torque lb-in (Nm)	Max. Input Speed (RPM)	Max. Radial Load lb (kg)	Nominal Ratio (x:1)	Overall Length in (mm) A	Pilot Mtg. in (mm) B	B.C. Diameter in (mm) C	Shaft Diam. in (mm)
G07	6,000 (680)	12,000 (1,360)	4,000	0	3.6	5.10 (129.54)	5.00 (127.00)	6.37 (161.80)	1.25 (31.75)
IA15	15,000 (1,695)	30,000 (3,390)	3,000	24,000 (10,909.09)	NA	15.00 (381.00)	6.00 (152.40)	9.00 (228.60)	3.00 (76.20)
IAB	1,850 (210)	3,700 (420)	3,000	1,800 (818.18)	NA	6.91 (175.50)	4.00 (101.06)	5.75 (146.00)	1.38 (34.90)
IAC	5,700 (644)	11,400 (1,288)	3,000	4,350 (1,977.27)	NA	9.36 (237.80)	5.00 (127.00)	6.38 (161.90)	1.50 (38.10)
IAD	15,000 (1,695)	30,000 (3,390)	3,000	9,000 (4,090.91)	NA	13.68 (347.40)	6.00 (152.40)	9.00 (228.60)	2.00 (50.80)
SICD	15,000 (1,695)	30,000 (3,390)	5,000	5,500 (2,500.00)	3 to 6	11.16 (283.46)	6.00 (152.40)	9.00 (228.60)	1.74 (44.20)

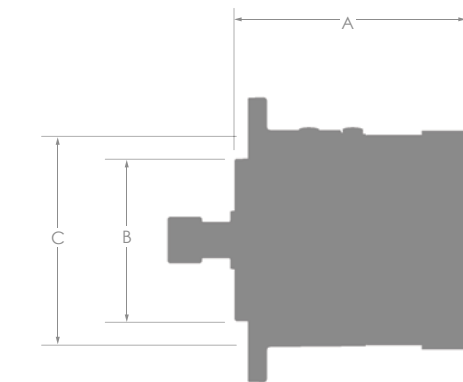

T-2 Two-Speed Drives

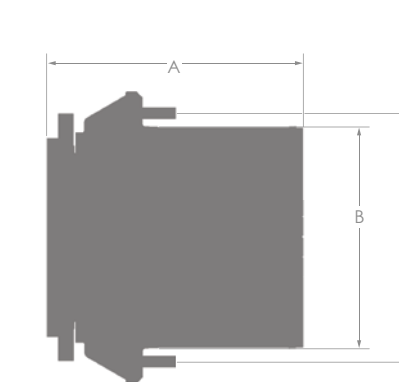

Torque II Two-Speed Drives

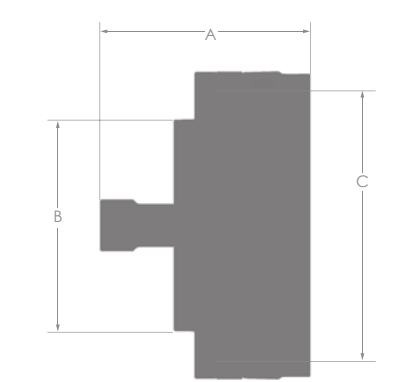

Special Add-On Adaptors