



Pressure transmitter with ratiometric output signal Type AKS 32R, AKS 2050

Introduction

AKS 32R is a ratiometric pressure transmitter that converts the measured pressure to a linear output signal. The min. value of the output signal is 10% of the actual supply voltage. The max. value is 90% of the actual supply voltage.

At a supply voltage of 5 V, a linear output signal is thus obtained, i.e.

- 0.5 V at min. pressure of the pressure transmitter
- 4.5 V at max. pressure of the pressure transmitter.

The robust design and the ratiometric output signal makes the transmitter suitable for systems together with ratiometric A/D converters within a number of fields:

- A/C systems
- Refrigeration plant
- CO₂ plant
- Process control
- Laboratories



AKS 2050 is for high pressure and with pulse-snubber in the pressure connection

Features

- Highly developed sensor technology means great regulation accuracy.
- Selective temperature compensation
- Compatible with all refrigerants incl. ammonia.
- Built-in voltage stabilizer
- Effective protection against moisture
- Robust construction gives protection against mechanical influences such as shock, vibration, and pressure surge
- EMC protected in accordance with the EU EMC-directive (CE-marked).
- Polarity protected inlets
- Output signal specially adjusted to ratiometric A/D-converters.
- Sealed gauge measuring principle (pressure reference = 1013 mbar).
- UL approved

Output signal

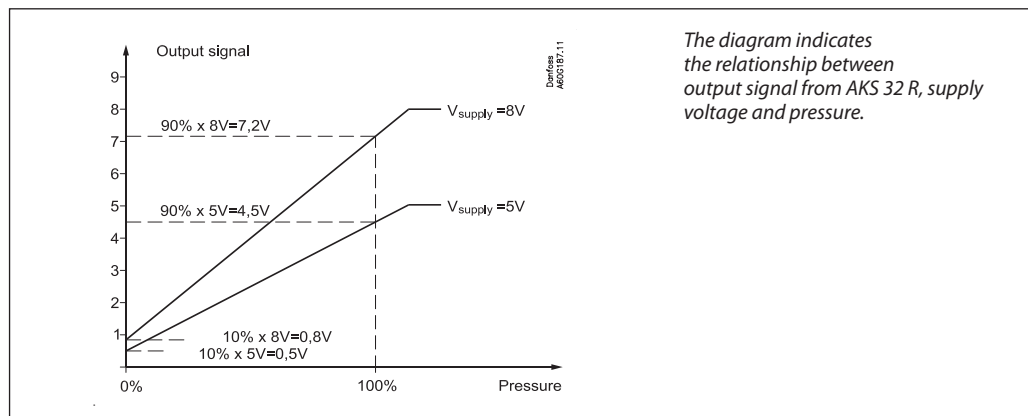

Connection for A/D converter

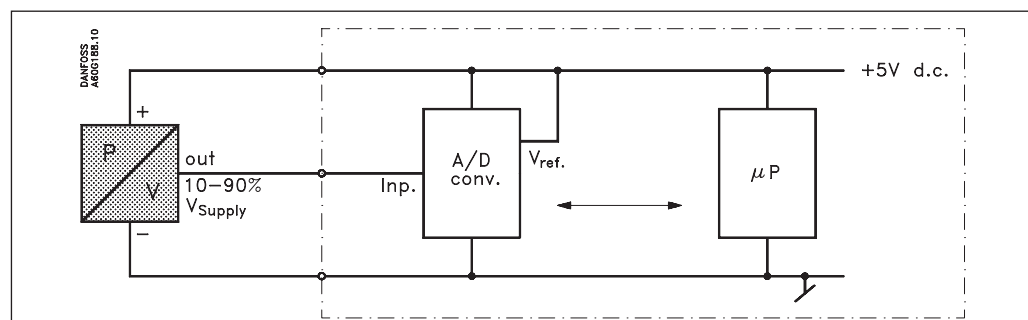

Technical data

Performance

Accuracy (incl. Linearity, Hysteresis and repeatability)	±0.5% FS (typ.) ±1.0% FS (max.)
Linearity deviation (Best fit straight line)	< ±0.2% FS
Hysteresis and repeatability	≤ ±0.1% FS
Thermal zero point operation	≤ ±0.1% FS/10K (typ.) ≤ ±0.2 %FS/10K (max.)
Thermal sensitivity operation	≤ ±0.1% FS/10K (typ.) ≤ ±0.2 %FS/10K (max.)
Response time	< 4 ms
Max. working pressure	See table page 4
Burst pressure	> 6 x FS

Electrical specifications

Nominal output signal (short-circuit protection)	10 to 90% af V_{supply}
Supply voltage, V_{supply} (polarity protection)	4.75 to 8 V d.c.
Power consumption, supply	< 5 mA at 5 V d.c.
Voltage dependence, supply	< 0.05% FS/10 V
Output impedance	< 25 Ω
Load resistance, R_L	$R_L \geq 10 \text{ k}\Omega$

Operating conditions

Operating temperature	-40 to 85°C			
Compensated temperature range	See ordering			
Transport temperature	-50 to 85°C			
EMC - Emission	EN 61000-6-3			
EMC - Immunity	Electrostatic discharge	Air 8 kV Contact 4 kV	EN 61000-6-2 EN 61000-6-2	
	RF	field	10 V/m, 26 MHz - 1 GHz	EN 61000-6-2
		conducted	3 V_{rms} , 150 kHz - 30 MHz	EN 61000-6-2
	Transient	Burst	4 kV (CM)	EN 61000-6-2
		Surge	1 kV (CM,DM)	EN 61000-6-2
Insulation resistance		> 100 M Ω at 100 V d.c.		
Operation frequency test	500 V, 50 Hz	SEN 361503		
Vibration stability	Sinusoidal	20 g, 25 Hz - 2 kHz	IEC 60068-2-6	
	Random	7,5 g_{rms} , 5 Hz - 1 kHz	IEC 60068-2-64	
Shock resistance	Shock	500 g / 1 ms	IEC 60068-2-27	
	Free fall		IEC 60068-2-32	
Enclosure	(IP protection fulfilled together with mating connector)	IP 65 - IEC 60529		

Approvals

UL recognized for sale in the USA and Canada	File no. E31024 File no. E227388
CE marked according to the EMC directive	89/ 336/ EC
Ex approval for sale in Europe	ATEX Ex II 3G Ex-nA IIAT3

Mechanical characteristics

Housing material and material in contact with medium	EN 10088-1. 1.4404 (AISI 316L)
Weight	0.3 kg

Dimensions and weight

Pressure connection	1/4-18 NPT	G 3/8 A ISO 228/1	1/4 in. flare 7/16-20 UNF
L [mm]	16	21	16.5

Weight approx. 0.3 kg

Pulse-snubber

Cavitation, liquid hammer and pressure peaks may occur in liquid filled systems with changes in flow velocity, e.g. fast closing of a valve or pump starts and stops. The problem may occur on the inlet and outlet side, even at rather low operating pressures.

Pulse-snubber in AKS 2050

Plug connections

Black → +
Blue → -
Brown → S

Cable

1 → +
2 → -
3 → S

Pg 9

Ordering

	Type	Operating range bar	Permissible working pressure PB bar	Compensated temp. range °C	Code no.			
					1/4 NPT 1)	G 3/8 A 2)	1/4 flare 3)	3/8 solder
	AKS 32R	-1 to 12	33	-30 to +40	060G1037	060G1038	060G1036	060G3551
		-1 to 34	55	0 to +80			060G0090	060G3552
	AKS 2050	-1 to 59	100	-30 to +40		060G5750		
		-1 to 99	150	-30 to +40		060G5751		
		-1 to 159	250	0 to +80		060G5752		
	Connecting plug with 5 m cable (mounted on pressure transmitter obtains IP67)				060G1034			
	Plug Pg 9				060G0008			

- 1) 1/4-18 NPT.
- 2) Thread ISO 228/1 - G 3/8 A (BSP).
- 3) 7/16-20 UNF.