



VLT® Power Options dU/dt filter



dU/dt filters reduce the dU/dt values on the motor terminal phase-to-phase voltage - an issue that is important for short motorcables. The phase-to-phase voltage is still pulse shaped.

Compared to sine-wave filters, dU/dt filters cut-off frequencies above the switching frequency. Having small inductance and capacitance, the filter is cheaper.

The filters reduce the motor insulation stress and are recommended in applications with risk of flashover. The fast voltage pulses of the switching frequency makes the motor act equivalent to a capacitor and not, as is the case of normal 50Hz applications, as an inductance. Inductance are added to the structure with every additional meter of motor cable and acts like a choke according to the energy storage principle.

The puls travelling times are thereby reduced.

Voltage overshoots and voltage peaks

Subject to voltage pulses, voltage peaks occur in the choke every time switching takes place. The higher inductance the higher voltage peaks causing stress situations in the winding insulation of the connected motor.

Owing to the cable impedance, the dU/dt stress – in the case of longer motor cables – is reduced to less problematical values.

On the basis of the line theory, however, peak values of 1600 V or more can occur due to cable reflections, which can have very steep dU/dt values.

According to VDE0530, peak values of <1000 V are permissible. Despite the reduced dU/dt owing to the cable impedance, this does not result in any significant stress relief for the motor, since now, the increased voltage amplitudes represent the dominant stress factor.

The perfect solution for:

- ▮ Applications with short motorcables
- ▮ Applications with older motors
- ▮ Aggressive environments
- ▮ Applications with frequent braking

Range

- 3 x 200 – 500 V
- 3 x 525 – 690 V

Features	Benefits
<ul style="list-style-type: none"> • Reduces du/dt stresses • Lower the magnetic interference propagation on surrounding cables and equipment 	<ul style="list-style-type: none"> • Increases motor service interval • Troublefree operation

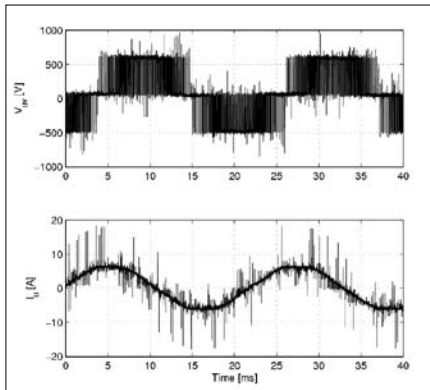

Voltage and current without filter

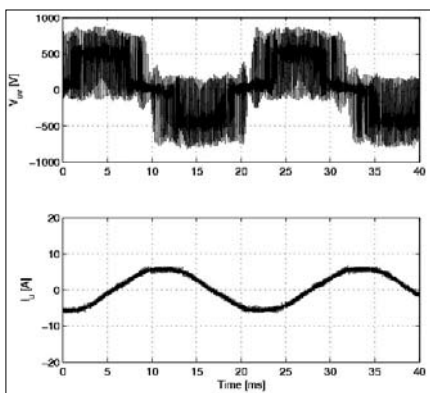

Voltage and current with filter

Specifications

Voltage rating	3 x 200 - 500 V and 3 x 525 - 690 V
Nominal current I_N @ 50 Hz	11 - 1200 Amp for higher power modules can be paralleled
Motor frequency	6-60 Hz without derating 120 Hz with derating
Ambient temperature	-25° to 40°C without derating
Min. switching frequency	f_{min} 1,5 kHz - 4 kHz depending on filter type
Max. switching frequency	f_{max} 8 kHz
Overload capacity	150 % for 60 sec every 10 min.
Enclosure degree	IP00 and IP20
Approvals	CE, UL508

Connection diagram

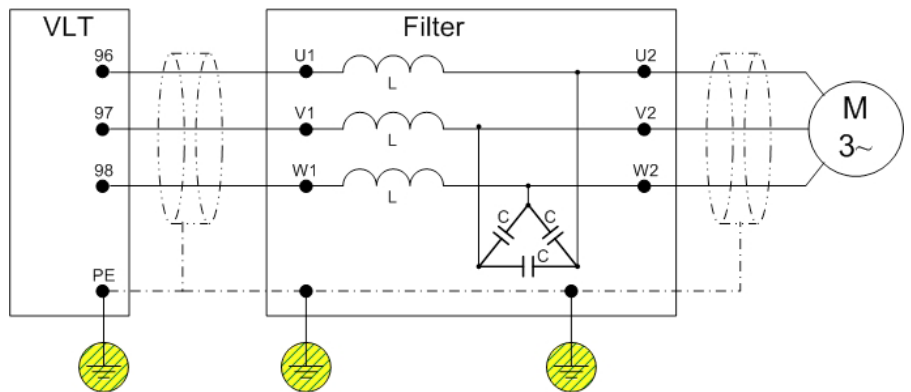

	Currents		Cabinet	Dimensions		
	500V [A]	690V [A]		Hight [mm]	Width [mm]	Depth [mm]
Wall Mount [IP20]	24	28	A1	181	75	205
			A2	246	90	205
			A3	246	120	205
			A4	246	130	205
			B1	260	150	260
	45-110	45-115	B2	380	150	260
			B3	285	170	260
			B4	460	170	260
			B5	540	170	260
			Floor Mount [IP21]	182-500	165-630	F1
F2	522	640				500
F3	522	670				500
750	530	F4		602	740	550
		F5		602	770	550
		F6		782	910	650
1500-2300	765-1350	F7		856	1150	860
		F8		1152	1260	800
		F9		1302	1304	860