



## **Thermostatic expansion valves**

**T2/TE2**

## Contents

	Page
Introduction.....	3
Features.....	3
Technical data.....	3
Superheat.....	3
Ordering:.....	4
Components with flare × flare connection.....	4
Flare connections.....	4
Orifice assembly with filter.....	4
Components with flare × solder connection.....	4
Solder adaptor.....	5
Orifice assembly with filter for solder adapter.....	5
Capacity:	
R22.....	6
R407C.....	7
R134a.....	8
R404A / R507.....	9
Design - Function.....	10
Identification.....	11
Dimensions and weights.....	11

Introduction



Thermostatic expansion valves regulate the injection of refrigerant liquid into evaporators. Injection is controlled by the refrigerant superheat. Therefore the valves are especially suitable for

liquid injection in "dry" evaporators where the superheat at the evaporator outlet is proportional to the evaporator load.

Features

- *Large temperature range*  
Equally applicable to freezing, refrigeration and air conditioning applications.
- *Interchangeable orifice assembly*
  - easier stocking
  - easy capacity matching
  - better service.
- *Rated capacities from 0.5 to 15.5 kW (0.15 to 4.5 TR) for R22.*
- *Can be supplied with MOP (Max. Operating Pressure)*  
Protects the compressor motor against excessive evaporating pressure during normal operation.
- *Stainless steel bulb*  
Fast and easy to install.  
Good temperature transfer from pipe to bulb.
- *Valves for special temperature ranges can be supplied.*

Technical data

*Max. temperature*  
Bulb, when valve is installed: 100°C  
Bulb, element not mounted: 60°C

*Max. test pressure*  
PT = 38 bar

*Min. temperature*  
T 2 → TE 2: -60°C

*Max. working pressure*  
PS/MWP = 34 bar

*MOP-points*

Refrigerant	Range N	Range NM	Range NL	Range B
	-40°C → +10°C	-40°C → -5°C	-40°C → -15°C	-60°C → -25°C
	MOP-point in evaporating temperature $t_e$ and evaporating pressure $p_e$			
	+15°C / +60°F	0°C / +32°F	-10°C / +15°F	-20°C / -4°F
R22	100 psig/6.9 bar	60 psig/4.0 bar	35 psig/3.5 bar	20 psig/1.5 bar
R407C	95 psig/6.6 bar			
R134a	55 psig/5.0 bar	30 psig/3.1 bar	15 psig/2.1 bar	
R404A/R507	120 psig/9.3 bar	75 psig/6.2 bar	50 psig/4.4 bar	30 psig/3.1 bar

Superheat

- SS = static superheat
- OS = opening superheat
- SH = SS + OS = total superheat
- $Q_{nom}$  = rated capacity
- $Q_{max}$  = maximum capacity

The standard superheat setting SS is 5 K for valves without MOP and 4 K for valves with MOP. The opening superheat OS is 6 K from when opening begins to where the valve gives its rated capacity  $Q_{nom}$ .

Static superheat SS can be adjusted with setting spindle.

*Example*  
Static superheat SS = 5 K  
Opening superheat OS = 6 K  
Total superheat SH = 5 + 6 = 11 K

## Ordering, components with flare × flare connection

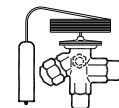

## Thermostatic element with sensor band, without orifice, filter cone, nuts

Refrigerant	Valve type	Pressure equalization <sup>1)</sup>	Capillary tube	Connection		Code no.					
				Inlet × outlet <sup>1)</sup>		Range N -40 to +10°C		Range NM -40 to -5°C	Range NL -40 to -15°C	Range B -60 to -25°C	
				m	in. × in.	mm × mm	Without MOP	With MOP	With MOP	With MOP	Without MOP
R22	TX 2	Int.	1.5	3/8 × 1/2	10 × 12	<b>068Z3206</b>	<b>068Z3208</b>	<b>068Z3224</b>	<b>068Z3226</b>	<b>068Z3207</b>	<b>068Z3228</b>
	TEX 2	Ext.	1.5	3/8 × 1/2	10 × 12	<b>068Z3209</b>	<b>068Z3211</b>	<b>068Z3225</b>	<b>068Z3227</b>	<b>068Z3210</b>	<b>068Z3229</b>
R407C	TZ 2	Int.	1.5	3/8 × 1/2	10 × 12	<b>068Z3496</b>	<b>068Z3516</b>				
	TEZ 2	Ext.	1.5	3/8 × 1/2	10 × 12	<b>068Z3501</b>	<b>068Z3517</b>				
R134a	TN 2	Int.	1.5	3/8 × 1/2	10 × 12	<b>068Z3346</b>	<b>068Z3347</b>	<b>068Z3393</b>	<b>068Z3369</b>		
	TEN 2	Ext.	1.5	3/8 × 1/2	10 × 12	<b>068Z3348</b>	<b>068Z3349</b>	<b>068Z3392</b>	<b>068Z3370</b>		
R404A/ R507	TS 2	Int.	1.5	3/8 × 1/2	10 × 12	<b>068Z3400</b>	<b>068Z3402</b>	<b>068Z3406</b>	<b>068Z3408</b>	<b>068Z3401</b>	<b>068Z3410</b>
	TES 2	Ext.	1.5	3/8 × 1/2	10 × 12	<b>068Z3403</b>	<b>068Z3405</b>	<b>068Z3407</b>	<b>068Z3409</b>	<b>068Z3404</b>	<b>068Z3411</b>

<sup>1)</sup> See the section "Flare connections".

## Flare connections



Connection for copper tubing with outside diameter		Reducer for copper tubing with outside diameter		Code no.
in.	mm	in.	mm	
1/4	6			<b>011L1101</b>
3/8	10			<b>011L1135</b>
1/2	12			<b>011L1103</b>
		1/4	6	<b>011L1107</b>

## Example

A TE 2 thermostatic expansion valve consists of two elements + flare nuts if required:

- 1 thermostatic element
- 1 orifice assembly and flare nuts

When ordering one thermostatic expansion valve, TEX 2 with orifice 01, five code numbers are required:

- 1-off thermostatic element, **068Z3209**
- 1-off orifice assembly 01, **068-2010**
- 1-off 3/8 in. flare nut, **011L1135**
- 1-off 1/2 in. flare nut, **011L1103**
- 1-off 1/4 in. flare nut, **011L1101**

## Orifice assembly with filter



## Range N: -40 to +10°C

Orifice no.	Rated capacity in tons (TR)				Rated capacity in kW				Code no. <sup>2)</sup>
	R22	R407C	R134a	R404A R507	R22	R407C	R134a	R404A R507	
0X	0.15	0.16	0.11	0.11	0.50	0.50	0.40	0.38	<b>068-2002</b>
00	0.30	0.30	0.25	0.21	1.0	1.1	0.90	0.70	<b>068-2003</b>
01	0.70	0.80	0.50	0.45	2.5	2.7	1.8	1.6	<b>068-2010</b>
02	1.0	1.1	0.80	0.60	3.5	3.8	2.6	2.1	<b>068-2015</b>
03	1.5	1.6	1.3	1.2	5.2	5.6	4.6	4.2	<b>068-2006</b>
04	2.3	2.5	1.9	1.7	8.0	8.6	6.7	6.0	<b>068-2007</b>
05	3.0	3.2	2.5	2.2	10.5	11.3	8.6	7.7	<b>068-2008</b>
06	4.5	4.9	3.0	2.6	15.5	16.7	10.5	9.1	<b>068-2009</b>

## Range B: -60 to -25°C

Orifice no.	Rated capacity in tons (TR)		Rated capacity in kW		Code no. <sup>2)</sup>
	R22	R404A R507	R22	R404A R507	
0X	0.15	0.11	0.50	0.38	<b>068-2002</b>
00	0.20	0.21	0.70	0.70	<b>068-2003</b>
01	0.30	0.45	1.0	1.6	<b>068-2010</b>
02	0.60	0.60	2.1	2.1	<b>068-2015</b>
03	0.80	1.0	2.8	3.5	<b>068-2006</b>
04	1.2	1.4	4.2	4.9	<b>068-2007</b>
05	1.5	1.7	5.2	6.0	<b>068-2008</b>
06	2.0	1.9	7.0	6.6	<b>068-2009</b>

The rated capacity is based on:  
 Evaporating temperature  $t_e = +5^\circ\text{C}$   
 for range N and  
 $t_e = -30^\circ\text{C}$  for range B  
 Condensing temperature  $t_c = +32^\circ\text{C}$   
 Refrigerant temperature ahead  
 of valve  $t_a = +28^\circ\text{C}$

<sup>2)</sup> These orifice assemblies cannot be used together with solder adapters. Please see adapter information on next page.

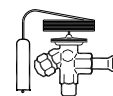
**Ordering, components with flare × solder connection**

*Thermostatic element with sensor band, without orifice, filter cone, nuts*

Refrigerant	Valve type	Pressure equalization <sup>3)</sup>	Capillary tube	Connection			Code no.				
				Inlet Flare	Outlet ODF solder		Range N -40 to +10°C		Range NL -40 to -15°C	Range B -60 to -25°C	
					in. / mm	in.	mm	Without MOP	MOP +15°C	Mop -10°C	Without MOP
<b>R22</b>	TX 2	Int.	1.5	<sup>3</sup> / <sub>8</sub>	<sup>1</sup> / <sub>2</sub>		<b>068Z3281</b>	<b>068Z3287</b>		<b>068Z3357</b>	<b>068Z3319</b>
	TX 2	Int.	1.5	10		12	<b>068Z3302</b>	<b>068Z3308</b>	<b>068Z3366</b>	<b>068Z3361</b>	<b>068Z3276</b>
	TEX 2	Ext.	1.5	<sup>3</sup> / <sub>8</sub>	<sup>1</sup> / <sub>2</sub>		<b>068Z3284</b>	<b>068Z3290</b>		<b>068Z3359</b>	<b>068Z3320</b>
	TEX 2	Ext.	1.5	10		12	<b>068Z3305</b>	<b>068Z3311</b>	<b>068Z3367</b>	<b>068Z3363</b>	<b>068Z3277</b>
<b>R407C</b>	TZ 2	Int.	1.5	<sup>3</sup> / <sub>8</sub>	<sup>1</sup> / <sub>2</sub>			<b>068Z3329</b>			
	TZ 2	Int.	1.5	10		12	<b>068Z3502</b>	<b>068Z3514</b>			
	TEZ 2	Ext.	1.5	<sup>3</sup> / <sub>8</sub>	<sup>1</sup> / <sub>2</sub>		<b>068Z3446</b>	<b>068Z3447</b>			
	TEZ 2	Ext.	1.5	10		12	<b>068Z3503</b>	<b>068Z3515</b>			
<b>R134a</b>	TN 2	Int.	1.5	<sup>3</sup> / <sub>8</sub>	<sup>1</sup> / <sub>2</sub>		<b>068Z3383</b>	<b>068Z3387</b>			
	TN 2	Int.	1.5	10		12	<b>068Z3384</b>	<b>068Z3388</b>			
	TEN 2	Ext.	1.5	<sup>3</sup> / <sub>8</sub>	<sup>1</sup> / <sub>2</sub>		<b>068Z3385</b>	<b>068Z3389</b>			
	TEN 2	Ext.	1.5	10		12	<b>068Z3386</b>	<b>068Z3390</b>			
<b>R404A/ R507</b>	TS 2	Int.	1.5	<sup>3</sup> / <sub>8</sub>	<sup>1</sup> / <sub>2</sub>		<b>068Z3414</b>	<b>068Z3416</b>	<b>068Z3429</b>	<b>068Z3418</b>	<b>068Z3420</b>
	TS 2	Int.	1.5	10		12	<b>068Z3435</b>	<b>068Z3423</b>	<b>068Z3436</b>	<b>068Z3425</b>	<b>068Z3427</b>
	TES 2	Ext.	1.5	<sup>3</sup> / <sub>8</sub>	<sup>1</sup> / <sub>2</sub>		<b>068Z3415</b>	<b>068Z3417</b>	<b>068Z3430</b>	<b>068Z3419</b>	<b>068Z3421</b>
	TES 2	Ext.	1.5	10		12	<b>068Z3422</b>	<b>068Z3424</b>	<b>068Z3437</b>	<b>068Z3426</b>	<b>068Z3428</b>

<sup>3)</sup>TE valves with inch outlet have 1/4 inch pressure equalization. TE valves with mm outlet have 6 mm pressure equalization.

**Solder adaptor**

The adaptor is for use with thermostatic expansion valves T 2 and TE 2 with flare × solder connections. When the adaptor is fitted correctly it meets the sealing requirements of DIN 8964.

The adaptor offers the following advantages:

- The orifice assembly can be replaced.
- The filter can be cleaned or replaced.

When using the solder adaptor, a special orifice assembly is required. Please use the following tables to select both the appropriate adaptor and orifice assembly.

Only in this way can the sealing requirements of DIN 8964 be fulfilled.

Solder adaptor for filter drier (FSA) may not be used in the T 2 inlet.

**Solder adaptor without orifice assembly and filter**

Connection ODF solder	Code no.
<sup>1</sup> / <sub>4</sub> in.	<b>068-2062</b>
6 mm	<b>068-2063</b>
<sup>3</sup> / <sub>8</sub> in.	<b>068-2060</b>
10 mm	<b>068-2061</b>

**Filter for solder adaptor**

Description	Code no.
Filter excl. orifice assembly	<b>068-0015</b>

Flare connections  
See previous page.

**Orifice assembly with filter for solder adaptor**

Orifice no.	Code no.
0X	<b>068-2089</b>
00	<b>068-2090</b>
01	<b>068-2091</b>
02	<b>068-2092</b>
03	<b>068-2093</b>
04	<b>068-2094</b>
05	<b>068-2095</b>
06	<b>068-2096</b>

For capacities see previous page.

Capacity

R22

Capacity in kW for range N: -40°C to +10°C

Valve type	Orifice no.	Pressure drop across valve Δp bar								Pressure drop across valve Δp bar							
		2	4	6	8	10	12	14	16	2	4	6	8	10	12	14	16
<b>Evaporating temperature +10°C</b>										<b>Evaporating temperature 0°C</b>							
TX 2/TEX 2-0.15	0X	0.37	0.48	0.55	0.60	0.63	0.65	0.65	0.67	0.37	0.48	0.55	0.59	0.63	0.65	0.66	0.66
TX 2/TEX 2-0.3	00	0.87	1.1	1.2	1.3	1.4	1.4	1.4	1.5	0.84	1.0	1.2	1.3	1.3	1.4	1.4	1.4
TX 2/TEX 2-0.7	01	2.2	2.8	3.2	3.4	3.6	3.7	3.8	3.8	1.9	2.4	2.7	3.0	3.1	3.2	3.3	3.3
TX 2/TEX 2-1.0	02	3.0	4.0	4.7	5.1	5.4	5.6	5.8	5.8	2.6	3.4	4.0	4.3	4.6	4.8	4.9	5.0
TX 2/TEX 2-1.5	03	5.4	7.2	8.3	9.1	9.7	10.0	10.2	10.3	4.6	6.1	7.1	7.8	8.2	8.5	8.7	8.8
TX 2/TEX 2-2.3	04	8.1	10.8	12.5	13.8	14.5	15.0	15.4	15.5	6.9	9.1	10.5	11.5	12.2	12.7	13.0	13.2
TX 2/TEX 2-3.0	05	10.2	13.6	15.7	17.2	18.3	18.9	19.3	19.5	8.8	11.6	13.3	14.6	15.5	16.1	16.4	16.6
TX 2/TEX 2-4.5	06	12.6	16.7	19.3	21.0	22.3	23.1	23.5	23.7	10.8	14.2	16.3	17.8	18.9	19.6	20.0	20.2
<b>Evaporating temperature -10°C</b>										<b>Evaporating temperature -20°C</b>							
TX 2/TEX 2-0.15	0X	0.37	0.47	0.53	0.57	0.60	0.63	0.64	0.64		0.44	0.50	0.54	0.57	0.59	0.61	0.61
TX 2/TEX 2-0.3	00	0.79	0.96	1.1	1.2	1.2	1.3	1.3	1.3	0.88	1.0	1.1	1.1	1.2	1.2	1.2	1.2
TX 2/TEX 2-0.7	01	1.6	2.0	2.3	2.5	2.6	2.7	2.8	2.8	1.7	1.9	2.0	2.2	2.3	2.3	2.3	2.3
TX 2/TEX 2-1.0	02	2.2	2.9	3.3	3.6	3.8	4.0	4.1	4.1	2.4	2.7	2.9	3.1	3.2	3.3	3.3	3.3
TX 2/TEX 2-1.5	03	3.9	5.1	5.9	6.4	6.8	7.1	7.3	7.3	4.2	4.8	5.2	5.5	5.8	5.9	6.0	6.0
TX 2/TEX 2-2.3	04	5.8	7.6	8.7	9.5	10.1	10.5	10.8	10.9	6.2	7.1	7.7	8.2	8.5	8.7	8.8	8.8
TX 2/TEX 2-3.0	05	7.4	9.6	11.0	12.0	12.8	13.3	13.6	13.8	7.9	9.0	9.8	10.3	10.8	11.0	11.2	11.2
TX 2/TEX 2-4.5	06	9.1	11.8	13.5	14.7	15.6	16.2	16.6	16.8	9.6	11.0	11.9	12.6	13.1	13.5	13.5	13.7
<b>Evaporating temperature -30°C</b>										<b>Evaporating temperature -40°C</b>							
TX 2/TEX 2-0.15	0X		0.40	0.45	0.49	0.52	0.55	0.56	0.57			0.42	0.45	0.48	0.50	0.52	0.53
TX 2/TEX 2-0.3	00		0.79	0.90	0.96	1.0	1.1	1.1	1.1			0.80	0.86	0.92	0.95	0.98	0.99
TX 2/TEX 2-0.7	01		1.4	1.5	1.7	1.8	1.8	1.9	1.9			1.3	1.4	1.4	1.5	1.5	1.6
TX 2/TEX 2-1.0	02		1.9	2.2	2.7	2.5	2.6	2.6	2.7			1.7	1.9	2.0	2.0	2.1	2.1
TX 2/TEX 2-1.5	03		3.4	3.9	4.2	4.4	4.6	4.7	4.8			3.1	3.4	3.5	3.7	3.8	3.8
TX 2/TEX 2-2.3	04		5.0	5.7	6.2	6.5	6.8	7.0	7.1			4.6	4.9	5.2	5.4	5.6	5.7
TX 2/TEX 2-3.0	05		6.4	7.2	7.8	8.3	8.6	8.8	9.0			5.8	6.3	6.6	6.9	7.1	7.2
TX 2/TEX 2-4.5	06		7.8	8.8	9.6	10.1	10.5	10.8	11.0			7.1	7.7	8.1	8.4	8.7	8.8

Capacity in kW for range B: -60°C to -25°C

Valve type	Orifice no.	Pressure drop across valve Δp bar								Pressure drop across valve Δp bar							
		2	4	6	8	10	12	14	16	2	4	6	8	10	12	14	16
<b>Evaporating temperature -25°C</b>										<b>Evaporating temperature -30°C</b>							
TX 2/TEX 2-0.2	00	0.69	0.83	0.94	1.0	1.1	1.1	1.1	1.2	0.66	0.79	0.89	0.96	1.0	1.1	1.1	1.1
TX 2/TEX 2-0.3	01	1.2	1.5	1.7	1.9	2.0	2.0	2.1	2.1	1.1	1.4	1.5	1.7	1.8	1.8	1.9	1.9
TX 2/TEX 2-0.6	02	1.7	2.1	2.4	2.6	2.8	2.9	2.9	3.0	1.5	1.9	2.2	2.3	2.5	2.6	2.6	2.7
TX 2/TEX 2-0.8	03	3.0	3.8	4.3	4.7	5.0	5.2	5.3	5.3	2.7	3.4	3.9	4.2	4.4	4.6	4.7	4.8
TX 2/TEX 2-1.2	04	4.4	5.6	6.4	6.9	7.3	7.6	7.8	7.9	3.9	5.0	5.7	6.2	6.5	6.8	7.0	7.1
TX 2/TEX 2-1.5	05	5.6	7.1	8.1	8.7	9.3	9.6	9.9	10.0	5.0	6.4	7.2	7.8	8.3	8.6	8.8	9.0
TX 2/TEX 2-2.0	06	6.8	8.7	9.8	10.7	11.3	11.8	12.1	12.3	6.1	7.8	8.8	9.6	10.1	10.5	10.8	11.0
<b>Evaporating temperature -40°C</b>										<b>Evaporating temperature -50°C</b>							
TX 2/TEX 2-0.2	00	0.60	0.71	0.80	0.86	0.92	0.95	0.98	0.99	0.54	0.65	0.72	0.78	0.82	0.85	0.87	0.88
TX 2/TEX 2-0.3	01	0.90	1.1	1.3	1.4	1.4	1.5	1.5	1.6	0.74	0.92	1.0	1.1	1.2	1.2	1.3	1.3
TX 2/TEX 2-0.6	02	1.2	1.6	1.7	1.9	2.0	2.1	2.1	2.1	1.0	1.3	1.4	1.5	1.6	1.7	1.7	1.7
TX 2/TEX 2-0.8	03	2.2	2.8	3.1	3.4	3.5	3.7	3.8	3.8	1.8	2.3	2.6	2.7	2.9	3.0	3.1	3.1
TX 2/TEX 2-1.2	04	3.2	4.0	4.6	4.9	5.2	5.4	5.6	5.7	2.6	3.3	3.7	4.0	4.2	4.4	4.5	4.6
TX 2/TEX 2-1.5	05	4.1	5.1	5.8	6.3	6.6	6.9	7.1	7.2	3.4	4.2	4.7	5.1	5.4	5.6	5.8	5.9
TX 2/TEX 2-2.0	06	5.0	6.3	7.1	7.7	8.1	8.4	8.7	8.8	4.1	5.1	5.8	6.2	6.6	6.9	7.1	7.2
<b>Evaporating temperature -60°C</b>																	
TX 2/TEX 2-0.2	00	0.50	0.60	0.66	0.71	0.75	0.77	0.79	0.80								
TX 2/TEX 2-0.3	01	0.64	0.79	0.88	0.95	1.0	1.0	1.1	1.1								
TX 2/TEX 2-0.6	02	0.9	1.1	1.2	1.3	1.4	1.4	1.4	1.4								
TX 2/TEX 2-0.8	03	1.6	1.9	2.2	2.3	2.4	2.5	2.6	2.6								
TX 2/TEX 2-1.2	04	2.2	2.8	3.1	3.4	3.6	3.7	3.8	3.9								
TX 2/TEX 2-1.5	05	2.9	3.6	4.0	4.3	4.6	4.8	4.9	5.0								
TX 2/TEX 2-2.0	06	3.5	4.4	4.9	5.3	5.6	5.8	6.0	6.1								

Correction for subcooling Δt<sub>sub</sub>

Note: Insufficient subcooling can produce flash gas.

The evaporator capacities used must be corrected if subcooling deviates from 4 K. The corrected capacity can be obtained by

Δt <sub>sub</sub>	4 K	10 K	15 K	20 K	25 K	30 K	35 K	40 K	45 K	50 K
Correction factor	1.00	1.06	1.11	1.15	1.20	1.25	1.30	1.35	1.39	1.44

dividing the required evaporator capacity by the correction factor below. Selections can then be made from the tables above.

Example  
Refrigerant = R22  
Evaporator capacity Q<sub>e</sub> = 5 kW  
Subcooling = 10 K

Correction factor from table = 1.06  
Corrected capacity = 5 : 1.06 = 4.72 kW

Capacity

**R407C**

Capacity in kW for range N: -40°C to +10°C

Valve type	Orifice no.	Pressure drop across valve Δp bar								Pressure drop across valve Δp bar							
		2	4	6	8	10	12	14	16	2	4	6	8	10	12	14	16
<b>Evaporating temperature +10°C</b>										<b>Evaporating temperature 0°C</b>							
TZ 2/TEZ 2 - 0.16	0X	0.40	0.50	0.56	0.61	0.63	0.64	0.63	0.64	0.40	0.50	0.56	0.60	0.63	0.64	0.64	0.63
TZ 2/TEZ 2 - 0.30	00	0.90	1.1	1.2	1.3	1.4	1.4	1.4	1.4	0.87	1.0	1.2	1.3	1.3	1.4	1.4	1.3
TZ 2/TEZ 2 - 0.80	01	2.3	2.9	3.3	3.4	3.6	3.6	3.7	3.6	2.0	2.5	2.8	3.0	3.1	3.1	3.2	3.2
TZ 2/TEZ 2 - 1.1	02	3.1	4.1	4.8	5.2	5.4	5.5	5.6	5.6	2.7	3.5	4.1	4.3	4.6	4.7	4.8	4.8
TZ 2/TEZ 2 - 1.6	03	5.6	7.4	8.5	9.2	9.7	9.8	9.9	9.9	4.8	6.3	7.2	7.9	8.2	8.3	8.4	8.4
TZ 2/TEZ 2 - 2.5	04	8.4	11.1	12.8	13.9	14.5	14.7	14.9	14.9	7.2	9.4	10.7	11.6	12.2	12.4	12.6	12.7
TZ 2/TEZ 2 - 3.2	05	10.6	14.0	16.0	17.4	18.3	18.5	18.7	18.7	9.2	11.9	13.6	14.7	15.5	15.8	15.9	15.9
TZ 2/TEZ 2 - 4.9	06	13.1	17.2	19.7	21.2	22.3	22.6	22.8	22.8	11.2	14.6	16.6	18.0	18.9	19.2	19.4	19.4
<b>Evaporating temperature -10°C</b>										<b>Evaporating temperature -20°C</b>							
TZ 2/TEZ 2 - 0.16	0X	0.38	0.48	0.54	0.57	0.60	0.62	0.62	0.61		0.45	0.51	0.54	0.56	0.57	0.59	0.57
TZ 2/TEZ 2 - 0.30	00	0.82	1.0	1.1	1.2	1.2	1.3	1.3	1.2		0.90	1.0	1.1	1.1	1.2	1.2	1.1
TZ 2/TEZ 2 - 0.80	01	1.7	2.0	2.3	2.5	2.6	2.6	2.7	2.7		1.7	1.9	2.0	2.2	2.2	2.2	2.2
TZ 2/TEZ 2 - 1.1	02	2.3	3.0	3.3	3.6	3.8	3.9	4.0	3.9		2.4	2.7	2.9	3.1	3.1	3.2	3.1
TZ 2/TEZ 2 - 1.6	03	4.1	5.2	6.0	6.4	6.8	7.0	7.1	6.9		4.3	4.8	5.2	5.4	5.6	5.7	5.6
TZ 2/TEZ 2 - 2.5	04	6.0	7.8	8.8	9.5	10.1	10.3	10.5	10.4		6.3	7.2	7.7	8.1	8.2	8.4	8.3
TZ 2/TEZ 2 - 3.2	05	7.7	9.8	11.1	12.0	12.8	13.0	13.2	13.1		8.1	9.1	9.8	10.2	10.5	10.6	10.5
TZ 2/TEZ 2 - 4.9	06	9.5	12.0	13.6	14.7	15.6	15.9	16.1	16.0		9.8	11.1	11.9	12.5	12.7	13.0	12.9
<b>Evaporating temperature -30°C</b>										<b>Evaporating temperature -40°C</b>							
TZ 2/TEZ 2 - 0.16	0X		0.41	0.45	0.49	0.51	0.53	0.53	0.53			0.42	0.44	0.46	0.48	0.48	0.49
TZ 2/TEZ 2 - 0.30	00		0.81	0.90	1.0	1.0	1.1	1.0	1.0			0.80	0.84	0.90	0.90	0.90	0.90
TZ 2/TEZ 2 - 0.80	01		1.4	1.5	1.7	1.8	1.7	1.8	1.8			1.3	1.4	1.3	1.4	1.4	1.5
TZ 2/TEZ 2 - 1.1	02		1.9	2.2	2.7	2.5	2.5	2.5	2.5			1.7	1.9	1.9	1.9	2.0	1.9
TZ 2/TEZ 2 - 1.6	03		3.5	3.9	4.2	4.3	4.4	4.5	4.5			3.1	3.3	3.4	3.5	3.5	3.5
TZ 2/TEZ 2 - 2.5	04		5.1	5.8	6.1	6.4	6.5	6.7	6.6			4.6	4.8	5.0	5.1	5.2	5.2
TZ 2/TEZ 2 - 3.2	05		6.5	7.3	7.7	8.1	8.3	8.4	8.4			5.8	6.2	6.3	6.6	6.6	6.6
TZ 2/TEZ 2 - 4.9	06		8.0	8.9	9.5	9.9	10.1	10.3	10.2			7.1	7.5	7.8	8.0	8.1	8.1

Correction for subcooling  $\Delta t_{sub}$

The evaporator capacities used must be corrected if subcooling deviates from 4 K. The corrected capacity can be obtained by

dividing the required evaporator capacity by the correction factor below. Selections can then be made from the tables above.

Note:  
Insufficient subcooling can produce flash gas.

$\Delta t_u$	4 K	10 K	15 K	20 K	25 K	30 K	35 K	40 K	45 K	50 K
Correction factor	1.00	1.08	1.14	1.21	1.27	1.33	1.39	1.45	1.51	1.57

## Capacity

**R134a**

Capacity in kW for range N: -40°C to +10°C

Valve type	Orifice no.	Pressure drop across valve $\Delta p$ bar					Pressure drop across valve $\Delta p$ bar				
		2	4	6	8	10	2	4	6	8	10
<b>Evaporating temperature +10°C</b>							<b>Evaporating temperature 0°C</b>				
TN 2/TEN 2 - 0.11	0X	0.34	0.43	0.47	0.50	0.51	0.33	0.42	0.46	0.47	0.49
TN 2/TEN 2 - 0.25	00	0.71	0.86	0.93	0.97	0.98	0.65	0.78	0.86	0.89	0.91
TN 2/TEN 2 - 0.5	01	1.5	1.9	2.1	2.2	2.2	1.3	1.6	1.7	1.8	1.8
TN 2/TEN 2 - 0.8	02	2.0	2.6	3.0	3.1	3.2	1.7	2.2	2.4	2.6	2.6
TN 2/TEN 2 - 1.3	03	3.6	4.7	5.3	5.6	5.8	3.0	3.9	4.4	4.6	4.7
TN 2/TEN 2 - 1.9	04	5.4	7.0	7.8	8.3	8.6	4.5	5.7	6.4	6.8	7.0
TN 2/TEN 2 - 2.5	05	6.9	8.9	9.9	10.8	10.9	5.7	7.3	8.1	8.6	8.8
TN 2/TEN 2 - 3.0	06	8.4	10.8	12.1	12.8	13.2	7.0	8.9	10.0	10.5	10.8
<b>Evaporating temperature -10°C</b>							<b>Evaporating temperature -20°C</b>				
TN 2/TEN 2 - 0.11	0X	0.30	0.38	0.43	0.44	0.44	0.28	0.35	0.39	0.41	0.42
TN 2/TEN 2 - 0.25	00	0.59	0.70	0.77	0.81	0.82	0.53	0.62	0.69	0.72	0.73
TN 2/TEN 2 - 0.5	01	1.0	1.3	1.4	1.5	1.5	0.81	1.00	1.1	1.2	1.2
TN 2/TEN 2 - 0.8	02	1.4	1.8	2.0	2.1	2.1	1.1	1.4	1.5	1.6	1.7
TN 2/TEN 2 - 1.3	03	2.5	3.1	3.5	3.7	3.8	2.0	2.5	2.8	2.9	3.0
TN 2/TEN 2 - 1.9	04	3.6	4.6	5.1	5.4	5.6	2.9	3.6	4.0	4.3	4.4
TN 2/TEN 2 - 2.5	05	4.6	5.8	6.5	6.9	7.1	3.7	4.6	5.1	5.4	5.5
TN 2/TEN 2 - 3.0	06	5.7	7.1	8.0	8.4	8.6	4.5	5.6	6.2	6.6	6.8
<b>Evaporating temperature -30°C</b>							<b>Evaporating temperature -40°C</b>				
TN 2/TEN 2 - 0.11	0X	0.25	0.32	0.35	0.37	0.38	0.23	0.28	0.32	0.33	0.34
TN 2/TEN 2 - 0.25	00	0.48	0.55	0.61	0.64	0.64	0.44	0.50	0.54	0.56	0.57
TN 2/TEN 2 - 0.5	01	0.66	0.80	0.88	0.93	0.95	0.54	0.65	0.72	0.76	0.77
TN 2/TEN 2 - 0.8	02	0.90	1.1	1.2	1.3	1.3	0.74	0.89	0.98	1.0	1.0
TN 2/TEN 2 - 1.3	03	1.6	2.0	2.2	2.3	2.3	1.3	1.6	1.8	1.9	1.9
TN 2/TEN 2 - 1.9	04	2.3	2.9	3.2	3.3	3.4	1.9	2.3	2.6	2.7	2.7
TN 2/TEN 2 - 2.5	05	3.0	3.6	4.0	4.2	4.3	2.4	2.9	3.2	3.5	3.5
TN 2/TEN 2 - 3.0	06	3.6	4.4	4.9	5.2	5.3	3.0	3.6	4.0	4.2	4.3

*Correction for subcooling  $\Delta t_{sub}$*

Note:  
Insufficient subcooling can produce flash gas.

The evaporator capacities used must be corrected if subcooling deviates from 4 K. The corrected capacity can be obtained by

dividing the required evaporator capacity by the correction factor below. Selections can then be made from the tables above.

$\Delta t_u$	4 K	10 K	15 K	20 K	25 K	30 K	35 K	40 K	45 K	50 K
Correction factor	1.00	1.08	1.13	1.19	1.25	1.31	1.37	1.42	1.48	1.54

Capacity

R404A / R507

Capacity in kW for range N: -40°C to +10°C

Valve type	Orifice no.	Pressure drop across valve Δp bar								Pressure drop across valve Δp bar							
		2	4	6	8	10	12	14	16	2	4	6	8	10	12	14	16
<b>Evaporating temperature +10°C</b>										<b>Evaporating temperature 0°C</b>							
TS 2/TES 2 - 0.11	0X	0.28	0.35	0.40	0.42	0.43	0.43	0.42	0.41	0.30	0.37	0.41	0.42	0.43	0.43	0.43	0.41
TS 2/TES 2 - 0.21	00	0.67	0.82	0.90	0.94	0.96	0.96	0.93	0.90	0.68	0.80	0.87	0.90	0.92	0.93	0.91	0.87
TS 2/TES 2 - 0.45	01	1.7	2.1	2.3	2.4	2.5	2.5	2.4	2.3	1.5	1.9	2.0	2.1	2.2	2.2	2.2	2.1
TS 2/TES 2 - 0.6	02	2.3	3.0	3.4	3.6	3.7	3.7	3.7	3.6	2.1	2.6	3.0	3.1	3.2	3.3	3.2	3.1
TS 2/TES 2 - 1.2	03	4.2	5.4	6.0	6.4	6.6	6.7	6.6	6.4	3.7	4.7	5.3	5.6	5.8	5.8	5.7	5.6
TS 2/TES 2 - 1.7	04	6.2	8.1	9.1	9.7	10.0	10.0	9.8	9.6	5.5	7.1	7.9	8.3	8.6	8.6	8.5	8.3
TS 2/TES 2 - 2.2	05	7.9	10.2	11.4	12.2	12.5	12.6	12.3	12.0	7.0	8.9	10.0	10.5	10.8	10.9	10.8	10.4
TS 2/TES 2 - 2.6	06	9.7	12.5	14.0	14.9	15.3	15.3	15.1	14.7	8.6	10.9	12.2	12.9	13.2	13.3	13.1	12.7
<b>Evaporating temperature -10°C</b>										<b>Evaporating temperature -20°C</b>							
TS 2/TES 2 - 0.11	0X	0.30	0.37	0.40	0.42	0.42	0.42	0.41	0.41		0.35	0.38	0.40	0.39	0.40	0.39	0.38
TS 2/TES 2 - 0.21	00	0.65	0.76	0.82	0.84	0.87	0.87	0.85	0.83		0.70	0.75	0.77	0.79	0.79	0.79	0.76
TS 2/TES 2 - 0.45	01	1.3	1.6	1.7	1.8	1.8	1.9	1.8	1.8		1.3	1.5	1.5	1.5	1.5	1.5	1.5
TS 2/TES 2 - 0.6	02	1.8	2.2	2.5	2.6	2.7	2.7	2.7	2.6		1.9	2.0	2.1	2.2	2.2	2.2	2.1
TS 2/TES 2 - 1.2	03	3.1	4.0	4.5	4.7	4.8	4.8	4.8	4.7		3.3	3.7	3.8	3.9	3.9	3.9	3.8
TS 2/TES 2 - 1.7	04	4.7	6.0	6.6	7.0	7.1	7.2	7.1	6.9		4.9	5.4	5.6	5.8	5.8	5.7	5.6
TS 2/TES 2 - 2.2	05	5.9	7.6	8.4	8.8	9.0	9.1	9.0	8.7		6.2	6.9	7.2	7.3	7.3	7.2	7.1
TS 2/TES 2 - 2.6	06	7.3	9.3	10.3	10.8	11.0	11.1	11.0	10.7		7.6	8.4	8.8	8.9	8.9	8.8	8.6
<b>Evaporating temperature -30°C</b>										<b>Evaporating temperature -40°C</b>							
TS 2/TES 2 - 0.11	0X			0.35	0.37	0.36	0.37	0.36	0.35			0.32	0.33	0.33	0.33	0.32	0.32
TS 2/TES 2 - 0.21	00			0.67	0.70	0.70	0.70	0.69	0.67			0.60	0.61	0.62	0.61	0.60	0.59
TS 2/TES 2 - 0.45	01			1.2	1.2	1.2	1.2	1.2	1.2			0.92	0.96	0.97	0.96	0.94	0.91
TS 2/TES 2 - 0.6	02			1.6	1.7	1.7	1.7	1.7	1.6			1.3	1.3	1.3	1.3	1.3	1.2
TS 2/TES 2 - 1.2	03			2.9	3.0	3.1	3.1	3.0	2.9			2.3	2.4	2.4	2.4	2.3	2.2
TS 2/TES 2 - 1.7	04			4.3	4.5	4.5	4.5	4.5	4.4			3.3	3.5	3.5	3.5	3.4	3.3
TS 2/TES 2 - 2.2	05			5.5	5.7	5.7	5.7	5.7	5.5			4.3	4.4	4.5	4.4	4.4	4.2
TS 2/TES 2 - 2.6	06			6.7	6.9	7.0	7.0	6.9	6.8			5.2	5.4	5.5	5.4	5.3	5.2

Capacity in kW for range B: -60°C to -25°C

Valve type	Orifice no.	Pressure drop across valve Δp bar								Pressure drop across valve Δp bar							
		2	4	6	8	10	12	14	16	2	4	6	8	10	12	14	16
<b>Evaporating temperature -25°C</b>										<b>Evaporating temperature -30°C</b>							
TS 2/TES 2 - 0.21	00	0.57	0.67	0.72	0.73	0.74	0.85	0.74	0.71	0.53	0.64	0.67	0.70	0.70	0.70	0.69	0.67
TS 2/TES 2 - 0.45	01	0.98	1.2	1.3	1.5	1.4	1.4	1.4	1.31	0.88	1.07	1.2	1.2	1.2	1.2	1.2	1.2
TS 2/TES 2 - 0.6	02	1.3	1.7	1.8	1.9	1.9	1.9	1.9	1.9	1.2	1.5	1.6	1.7	1.7	1.7	1.7	1.6
TS 2/TES 2 - 1.0	03	2.4	3.0	3.3	3.4	3.5	3.5	3.4	3.3	2.1	2.7	2.9	3.0	3.1	3.1	3.0	2.9
TS 2/TES 2 - 1.4	04	3.5	4.4	4.8	5.0	5.1	5.1	5.1	4.9	3.1	3.9	4.3	4.5	4.5	4.5	4.5	4.4
TS 2/TES 2 - 1.7	05	4.4	5.6	6.1	6.4	6.5	6.5	6.4	6.3	3.9	4.9	5.5	5.7	5.7	5.7	5.7	5.5
TS 2/TES 2 - 1.9	06	5.4	6.8	7.5	7.8	7.9	7.9	7.9	7.6	4.8	6.1	6.7	6.9	7.0	7.0	6.9	6.8
<b>Evaporating temperature -40°C</b>										<b>Evaporating temperature -50°C</b>							
TS 2/TES 2 - 0.21	00		0.56	0.60	0.61	0.62	0.61	0.60	0.59		0.49	0.53	0.54	0.54	0.53	0.52	0.50
TS 2/TES 2 - 0.45	01		0.85	0.92	0.96	0.97	0.96	0.94	0.91		0.51	0.57	0.60	0.60	0.60	0.60	0.59
TS 2/TES 2 - 0.6	02		1.2	1.3	1.3	1.3	1.3	1.3	1.2		0.91	0.99	1.0	1.0	1.0	0.98	0.95
TS 2/TES 2 - 1.0	03		2.1	2.3	2.4	2.4	2.4	2.3	2.2		1.6	1.8	1.8	1.8	1.8	1.8	1.7
TS 2/TES 2 - 1.4	04		3.0	3.3	3.5	3.5	3.5	3.4	3.3		2.4	2.6	2.7	2.7	2.7	2.6	2.6
TS 2/TES 2 - 1.7	05		3.9	4.3	4.4	4.5	4.4	4.4	4.2		3.0	3.3	3.4	3.5	3.4	3.4	3.3
TS 2/TES 2 - 1.9	06		4.7	5.2	5.4	5.5	5.5	5.3	5.2		3.7	4.0	4.2	4.2	4.2	4.1	4.0
<b>Evaporating temperature -60°C</b>																	
TS 2/TES 2 - 0.21	00			0.46	0.48	0.47	0.45	0.45	0.43								
TS 2/TES 2 - 0.45	01			0.58	0.60	0.60	0.58	0.56	0.54								
TS 2/TES 2 - 0.6	02			0.78	0.80	0.80	0.78	0.75	0.72								
TS 2/TES 2 - 1.0	03			1.4	1.4	1.4	1.4	1.4	1.3								
TS 2/TES 2 - 1.4	04			2.0	2.1	2.1	2.1	2.0	2.0								
TS 2/TES 2 - 1.7	05			2.6	2.7	2.7	2.7	2.6	2.5								
TS 2/TES 2 - 1.9	06			3.2	3.3	3.3	3.3	3.2	3.1								

Correction for subcooling Δt<sub>sub</sub>

The evaporator capacities used must be corrected if subcooling deviates from 4 K. The corrected capacity can be obtained by

dividing the required evaporator capacity by the correction factor below. Selections can then be made from the tables above.

Note:  
Insufficient subcooling can produce flash gas.

Δt <sub>u</sub>	4 K	10 K	15 K	20 K	25 K	30 K	35 K	40 K	45 K	50 K
Correction factor	1.00	1.10	1.20	1.29	1.37	1.46	1.54	1.63	1.70	1.78

**Design  
Function**

*General*

T 2 and TE 2 valves have an interchangeable orifice assembly.

For the same valve type and refrigerant, the associated orifice assembly is suitable for all versions of valve body and in all evaporating temperature ranges.

The charge in the thermostatic element depends on the evaporating temperature range.

The valves can be equipped with internal (T 2) or external (TE 2) pressure equalization.

External pressure equalization should always be used on systems with liquid distributors.

The double contact bulb gives fast and precise reaction to temperature changes in the evaporator. It also makes fitting the bulb quick and easy.

The valves are able to withstand the effects that normally occur with hot gas defrosting.

To ensure long operating life, the valve cone and seat are made of a special alloy with particularly good wear qualities.

- 1. Thermostatic element (diaphragm)
- 2. Interchangeable orifice assembly
- 3. Valve body
- 4. Superheat setting spindle (see instructions)

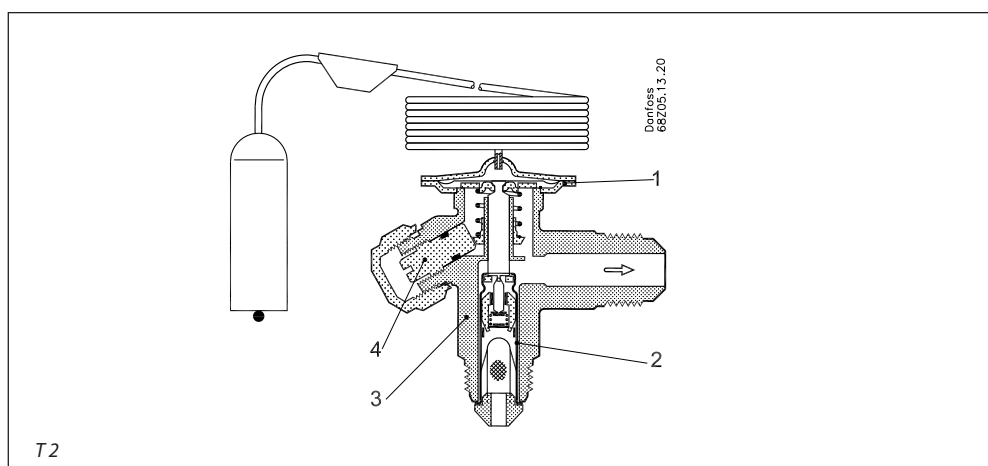

**Identification**

The thermostatic element is fitted with a laser engraving on top of the diaphragm. This engraving gives valve type (with code number), evaporating temperature range, MOP point, refrigerant, and max. working pressure, PS/MWP.

The code refers to the refrigerant for which the valve is designed:

- X = R22
- Z = R407C
- N = R134a
- S = R404A/ R507

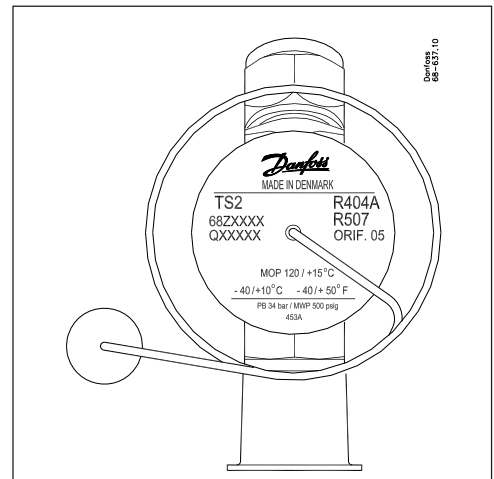

*Orifice assembly for T 2 and TE 2*

The orifice assembly is marked with the orifice size (e.g. 06) and week stamp + last number in the year (e.g. 174). The orifice assembly number is also given on the lid of its plastic container.

Orifice assembly and filter for T 2 and TE 2

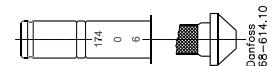

*Capillary tube label for T 2 and TE 2*

The label gives the orifice size (04) and consists of the lid of the orifice assembly plastic container. It can easily be fastened around the expansion valve capillary tube to clearly identify the valve size.

Capillary tube label T 2 and TE 2

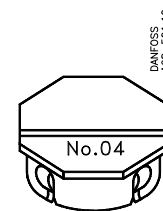

**Dimensions and weights**

*T 2 and TE 2*

	Outlet A	Equalization B	Weight kg / lb
Flare x flare	1/2" flare	1/4" flare	0.3 / 0.7
Flare x solder	1/2" solder 12 mm solder	1/4" solder 6 mm solder	0.3 / 0.7

ODF	
in.	mm
1/4	6
3/8	10

